

Altoway AltoPlex Series P421 User Guide

Version 4.2.0
December 4, 2025

Copyright, trademark, and legal information

Note: This equipment has been tested and found to comply with the limits for a Class B digital device, pursuant to part 15 of the FCC Rules. These limits are designed to provide reasonable protection against harmful interference in a residential installation. This equipment generates, uses and can radiate radio frequency energy and, if not installed and used in accordance with the instructions, may cause harmful interference to radio communications. However, there is no guarantee that interference will not occur in a particular installation. If this equipment does cause harmful interference to radio or television reception, which can be determined by turning the equipment off and on, the user is encouraged to try to correct the interference by one or more of the following measures:

- Reorient or relocate the receiving antenna.
- Increase the separation between the equipment and receiver.
- Connect the equipment into an outlet on a circuit different from that to which the receiver is connected.
- Consult the dealer or an experienced radio/TV technician for help.

Any modifications to this product which are not authorized by Altowav Inc. could void your authority to operate this equipment.

THE SPECIFICATIONS AND INFORMATION REGARDING THE PRODUCTS IN THIS MANUAL ARE SUBJECT TO CHANGE WITHOUT NOTICE. ALL STATEMENTS, INFORMATION, AND RECOMMENDATIONS IN THIS MANUAL ARE BELIEVED TO BE ACCURATE BUT ARE PRESENTED WITHOUT WARRANTY OF ANY KIND. USERS MUST TAKE FULL RESPONSIBILITY FOR THEIR APPLICATION OF ANY PRODUCT.

NOTWITHSTANDING ANY OTHER WARRANTY HEREIN, ALL DOCUMENT FILES AND SOFTWARE ARE PROVIDED "AS IS" WITH ALL FAULTS. ALTOWAV DISCLAIMS ALL WARRANTIES, EXPRESSED OR IMPLIED, INCLUDING, WITHOUT LIMITATION, THOSE OF MERCHANTABILITY, FITNESS FOR A PARTICULAR PURPOSE AND NON-INFRINGEMENT OR ARISING FROM A COURSE OF DEALING, USAGE, OR TRADE PRACTICE.

IN NO EVENT SHALL ALTOWAV OR ITS SUPPLIERS BE LIABLE FOR ANY INDIRECT, SPECIAL, CONSEQUENTIAL, OR INCIDENTAL DAMAGES, INCLUDING, WITHOUT LIMITATION, LOST PROFITS OR LOSS OF DAMAGE TO DATA ARISING OUT OF THE USE OR INABILITY TO USE THIS MANUAL, EVEN IF ALTOWAV HAS BEEN ADVISED OF THE POSSIBILITY OF SUCH DAMAGES.

Altowav would like to thank all of our staff for their efforts and expertise in development and implementation of the P421.

© 2024-2025 Altowav Inc. All rights reserved.

Altowav™, AltoPlex™, and AltoCommand™ are trademarks of Altowav Inc. Kwikbit™, and Kwikbit Networks™ are trademarks of Kwikbit Internet.

All trademarks, logos and brand names are the property of their respective owners.

Regulatory statements

FCC Radiation Exposure Statement

The P421 device complies with FCC radiation exposure limits set forth for an uncontrolled environment. A minimum of 35 centimeters (14 inches) of separation between the P421 and all persons shall be maintained.

FCC Regulatory Statement

The P421 equipment has been tested and found to comply with the limits for a Class B digital device, pursuant to Part 15 of the FCC Rules. For full Regulatory notices and statements, refer to the manufacturer and product as declared on the hardware label.

ISED Industry Canada Radiation Exposure Statement

IC Radiation Exposure Statement:

The P421 device complies with IC RSS-102 radiation exposure limits set forth for an uncontrolled environment. A minimum of 35 centimeters of separation between the P421 and all persons shall be maintained.

Cet équipement est conforme aux limites d'exposition aux rayonnements IC établies pour un environnement non contrôlé. Un minimum de 35 centimètres de séparation entre le P421 et toutes les personnes doit être maintenu.

ISED Industry Canada Regulatory Statement

The P421 device complies with Industry Canada licence-exempt RSS standard(s). This device contains license-exempt transmitter(s)/receivers(s) that comply with Innovation, Science and Economic Development Canada's license-exempt RSS(s). Operation is subject to the following two conditions:

- (1) This device may not cause interference.
- (2) This device must accept any interference, including interference that may cause undesired operation of the device.

This device is not to be operated on aircraft or satellites (ISED RSS-210 Annex J).

Cet appareil contient des émetteurs/récepteurs exempts de licence qui sont conformes aux CNR exempts de licence d'Innovation, Sciences et Développement économique Canada. Son fonctionnement est soumis aux deux conditions suivantes :

- (1) Cet appareil ne doit pas causer d'interférences.
- (2) Cet appareil doit accepter toute interférence, y compris celles qui peuvent entraîner un fonctionnement indésirable de l'appareil.

Cet appareil ne doit pas être utilisé à bord d'un avion ou de satellites (l'Annexe J de la norme ISED RSS-210).

EU regulatory notes

This product meets the technical requirements of EC Decision (2006/771/EC) on harmonization of the radio spectrum for use by short range devices, band number 75a with operation between 57 GHz and 66 GHz and a maximum radiated transmit power of 40 dBm e.i.r.p.

Altowav has issued Declarations of Conformity for this product. See support.altowav.com for further information.

Specific guidelines with regard to outdoor operation of 60 GHz radios vary by EU member country. Refer to the radio regulatory agency in the country of operation for more information.

This product includes a 2.4 GHz radio with operation between 2412-2472MHz frequency range and a maximum radiated transmit power of 19.99 dBm e.i.r.p.



Changes or modifications to this equipment not approved by Altowav or the party responsible for compliance could void the user's authority to use the product.



Outdoor radios should be installed by experienced installation professionals who are familiar with local building and safety codes, and who are, when applicable, licensed by the appropriate regulatory authorities. Failure to do so may void the product warranty and may expose the end user or the service provider to legal and financial liabilities. Altowav and its resellers and distributors are not liable for injury, damage, or violation of regulations associated with the installation of outdoor radios.

Recommended radio frequency exposure exclusion zone

In compliance with the [ICNIRP 2020 Guidelines](#) and the following regulations for limiting exposure to electromagnetic fields:

- USA — [FCC 47CFR1.1310](#)
- Canada — [ISED Safety Code 6 \(2015\)](#)
- Europe — [EC Recommendation \(1999/519/EC\)](#) and [Directive 2013/35/EU](#)

The following table lists the recommended RF exposure exclusion zone for the P421:

General public/ Uncontrolled environment	Occupational/Controlled environment
35 cm	15cm

Restrictions statement



BE	BG	CZ	DK	DE	EE	IE
EL	ES	FR	HR	IT	CY	LV
LT	LU	HU	MT	NL	AT	PL
PT	RO	SI	SK	FI	SE	UK(NI)
NO	IS	LI	CH	TR		

For the European Union, you must check with your national authority for any restrictions. Restrictions may apply in some countries where outdoor use is not allowed. Licensing is required for the UK prior to use.

Revision history

Revision	Date
<p>Updated for the 4.2.0 software release:</p> <ul style="list-style-type: none"> • Added information about changing the SSID and encryption passkey for the 60 GHz airlink. • Added description of the new Link State parameter in the Wireless table on the Status tab, and the Wireless Status table on the Wireless tab, of the WebUI. • Added information about a new Hide SSID configuration parameter that hides the diagnostic Wi-Fi SSID. 	12/04/2025
<p>Updated for the 3.9.1 software release:</p> <ul style="list-style-type: none"> • Added information about AltoCommand Cloud Connection. (This feature requires AltoCommand version 4.0.) • Added regulatory information for ETSI certification. 	08/11/2025
<p>Updated for the 3.6.0 software release:</p> <ul style="list-style-type: none"> • Added MAC filtering. • Added information about the factory default fallback static IP address of 192.168.0.1, new to release 3.6.0. • Added link to the AltoWay enterprise MIB 	05/05/2025
<p>Updated for the 3.3.1 release:</p> <ul style="list-style-type: none"> • LL Discovery information added to the Status page . • Updated VLAN configuration information. • Upgrading Firmware procedures updated. 	02/05/2025
<p>Updates to graphics and other minor updates.</p>	01/13/2025
<p>Initial release of the P421.</p>	12/18/2024

Contents

P421 User Guide overview	7
Additional Documents.....	7
Additional help	7
Introduction	8
P421 Installation and Configuration.....	9
Network topology design and deployment.....	9
Preparing for installation	15
Connecting to the P421	23
Installation.....	26
Configuration	29
Maintenance and security	53
Wi-Fi connection to a P421	53
Change the device password.....	55
Enable Passwordless SSH	56
Upgrading firmware.....	57
Reboot a device	64
Factory reset	65
Troubleshooting.....	67
LED Indicators.....	68
Lost Password.....	70
Download a Diagnostic File.....	70
MAC addresses used by the P421	72
Glossary.....	73

P421 User Guide overview

Thank you for choosing the Altowav AltoPlex series for your fixed-point networking solution. This user guide describes installation, configuration and operations of P421 devices.

This guide is intended for network and system administrators who will install, configure, and manage Altowav networks using P421 devices.

This guide includes instructions for the installation, configuration and management of P421 devices using the WebUI. Other methods of device and network management, such as the Command Line Interface (CLI), REST API and the AltoCommand network management tool, are mentioned, but detailed instructions are not provided.

It is assumed readers are familiar with:

- Basic networking concepts.
- Routing and switching in networks.
- Specific network practices, operations and settings at the installation.
- The topology of the network being installed and managed.

Additional Documents

Further information about the P421 devices:

- For general technology specifications and product datasheets, see altowav.com/technology/
- [P421 Quick Start](#)
- [Altowav AltoCommand User Guide](#)

Additional help

Altowav is committed to providing our customers with high quality technical support.

Web	support.altowav.com
-----	--

E-mail	support@altowav.com
--------	--

Introduction

Designed to help service providers deliver an excellent customer experience while managing costs, the AltoPlex platform utilizes carrier-grade gigabit connectivity to provide wireless network access. The platform enables highly customizable network management without the need for a centralized controller.

The AltoPlex platform delivers the superior performance and rich feature set promised by 802.11ay, with a lower cost and simplified management, as compared to our competitors in the 60 GHz solution marketplace.

With the AltoPlex platform, service providers can deploy and manage small to very large networks cost-effectively, and support many applications including:

- Gigabit fixed-wireless access (FWA).
- Surveillance camera connectivity.
- Multi-dwelling unit distribution.

The AltoPlex platform includes a REST API, providing the flexibility for network administrators to use the monitoring and management systems of their choice.

P421 Installation and Configuration

Network topology design and deployment

The P421 has a weatherproof form factor with wireless coverage for 90° sector and a single RJ45 port. As with other AltoPlex devices, they require stable power, secure mounting, and a clear line-of-sight (LOS), to form a wireless connection.



The P421 is designed to operate in a point-to-point deployment with other P421s.

About AltoPlex wireless links

- 60GHz wireless links rely on clear line of sight (LOS).
- When delivered as part of a bridge kit, P421s automatically pair with each other.
- Weighted MCS levels are a good performance metric for the AltoPlex products. Power control in the P421 adjusts automatically to drive optimal MCS levels.

P421 — General information

Capacity/throughput: 2 Gbps Aggregate

Range: Expected maximum range for a P421-to-P421 link: Up to 1,312 feet (400 meters).

Ethernet: One 2.5 Gbps RJ45 port. Requires a PoE connection.

Scan range: 90° azimuth (-45° to 45°) for a single wireless sector. 40° elevation range. Mounting hardware provides additional aiming flexibility.

Maximum DN-to-DN links: 1 per radio interface.

GPS: Used for location and synchronization.

Wi-Fi management: A [Wi-Fi access point](#) is enabled by default for management and diagnostic purposes. The AP provides access to the radio only; it does not provide network or internet access.

Deployment for common topologies

Altoway recommends creating a detailed network design and deployment plan with specific device, network and location information. The following example is a general illustration of a network design plan; your specific situation will vary. Channel and golay code settings should be selected based on the deployment specifics; see [Design Issues to Avoid](#) for details about using channel and golay code settings.

Considerations for all deployments:

- The P421 is a dedicated point-to-point device. As a result, each P421 supports one link to another P421. No additional links are supported.
- Generally, all DNs on the same pole should have the same polarity. If your network requires opposite polarities on the same pole, make sure that the devices are set to different channels.
- Keep in mind performance and operational characteristics of the P421 for range, and throughput, as listed above.
- Follow [Installation](#) guidelines.

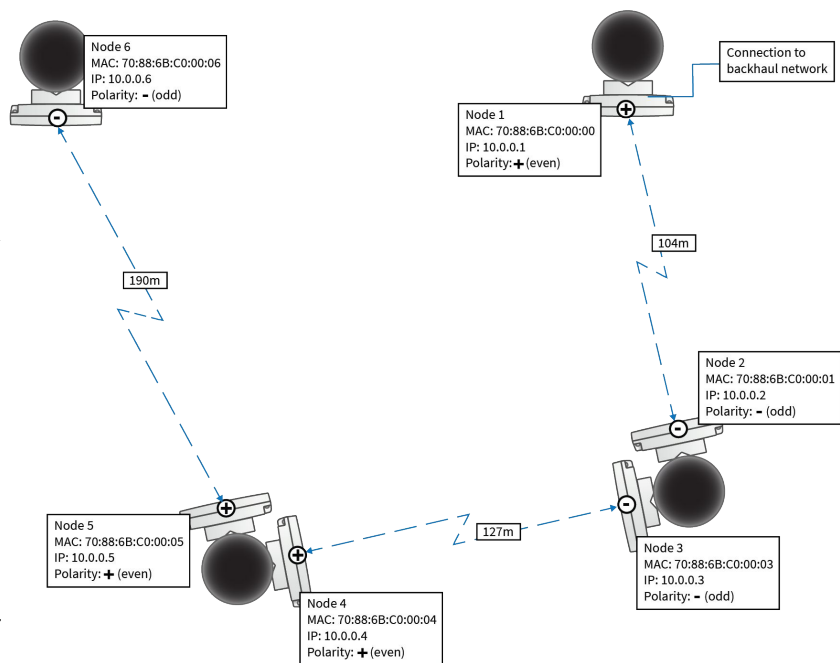

Point-to-point deployment

Point-to-point deployments involve two P421s linked together in a serial fashion.

Simple point-to-point topology between two P421s

The following diagram demonstrates a simple point-to-point topology between two P421s.

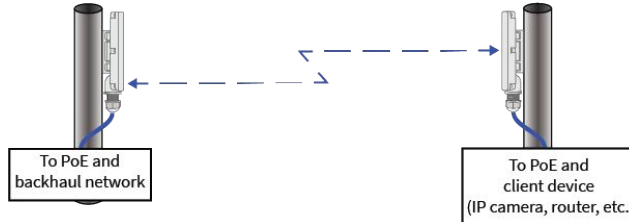

Point-to-point topology with multiple P421s (daisy-chain)

The following diagram demonstrates several P421s linked together in a serial fashion.

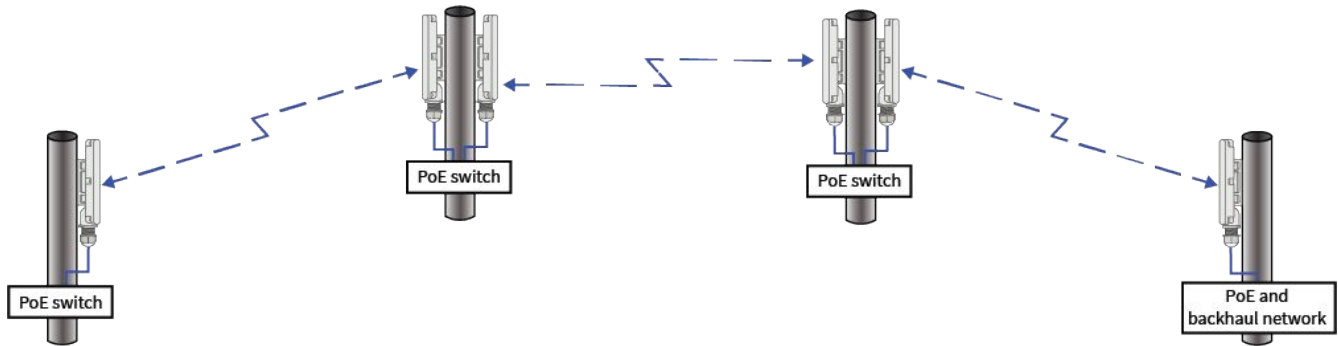

Ring deployment

A ring deployment is a standard topology for AltoPlex deployments, and can be used to provide redundant backup network connections by utilizing Rapid Spanning Tree Protocol (RSTP). RSTP should be enabled for ring topologies and is enabled by default.

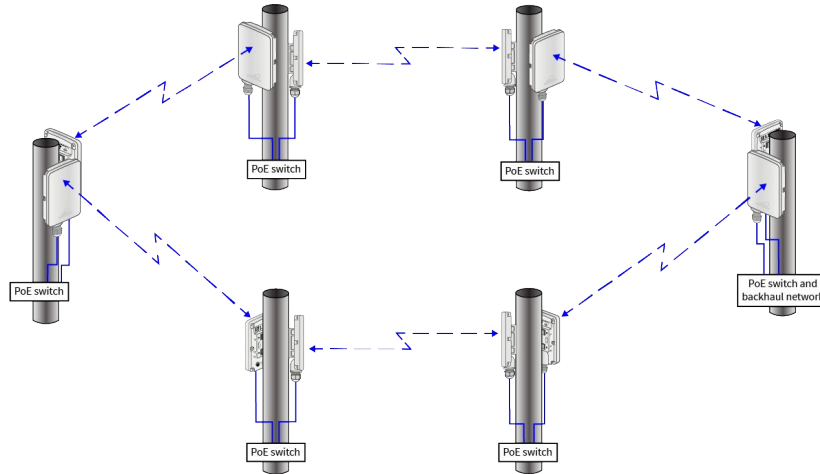

Spur or Spoke Deployment

A spur or spoke deployment extends the reach of a distribution network. At least two P421s are required at the spur switch point that extends distribution to a wider azimuth range.

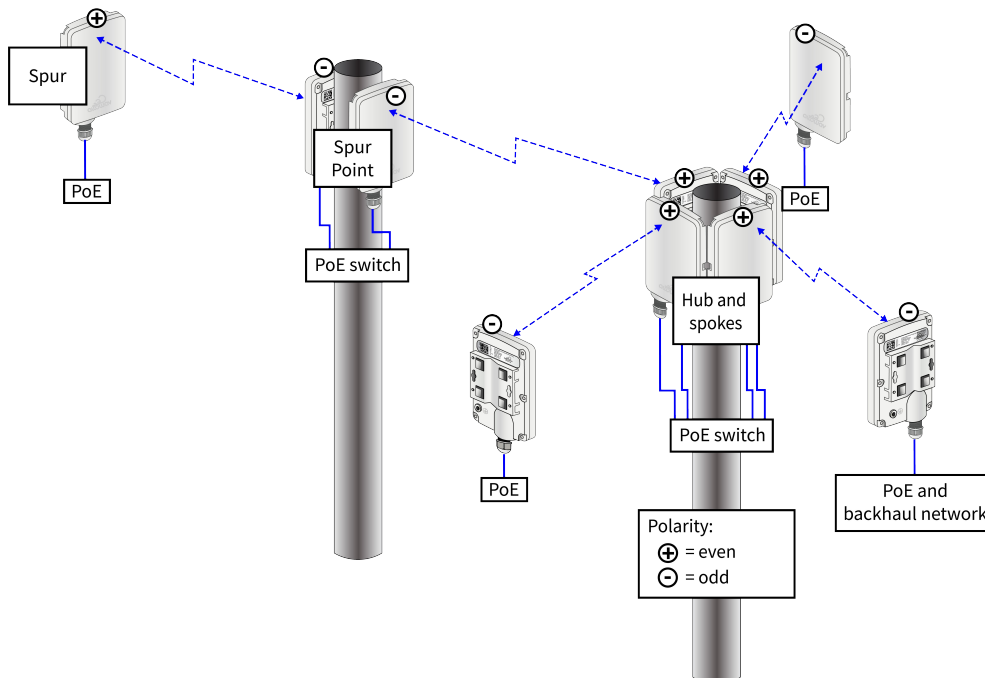

Design Issues to Avoid

The following describe common problems with design issues for 60GHz networks running on 802.11ay-based technology.

Issue: P421s in a straight line and close together

When three or more P421 links are in a line and are using the same channel and golay code, a signal can be far reaching and cause interference to an unintended endpoint. Straight line interference is more impactful for short link distances.

The diagram below shows transmission using the same channel and golay index. In this case, signal A can also cause a signal D that may interfere with an unintended endpoint.

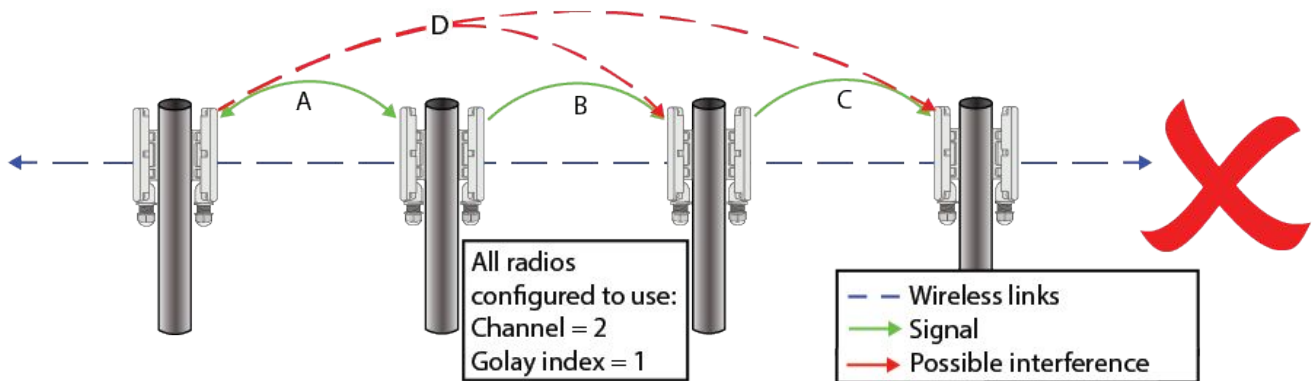

Solutions:

- **Set the Golay index (1-3) for both ends of each link.** Make sure that the Golay index is different for the link between the two DNs with the possible signal interference.

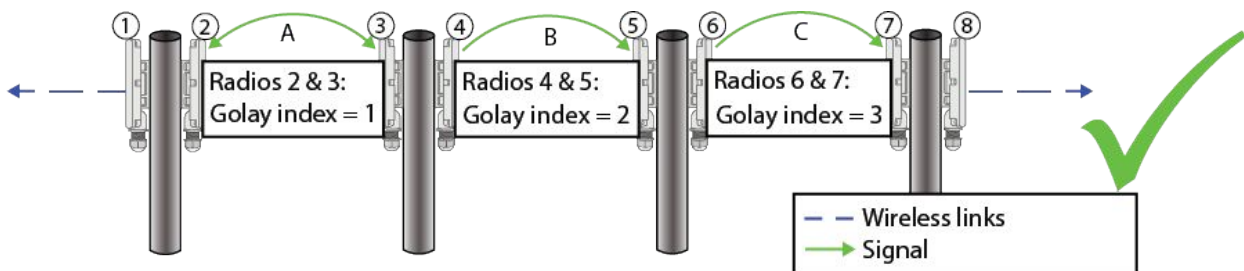

- Less optimal solution:** Use different channels (1-4) between the distribution nodes. This provides a reliable solution, if network design and short link distances require it. However, in general practice the same channel is used in straight line formation to avoid adjacent sector interference and provide more flexible options for channel selection on adjacent sectors.

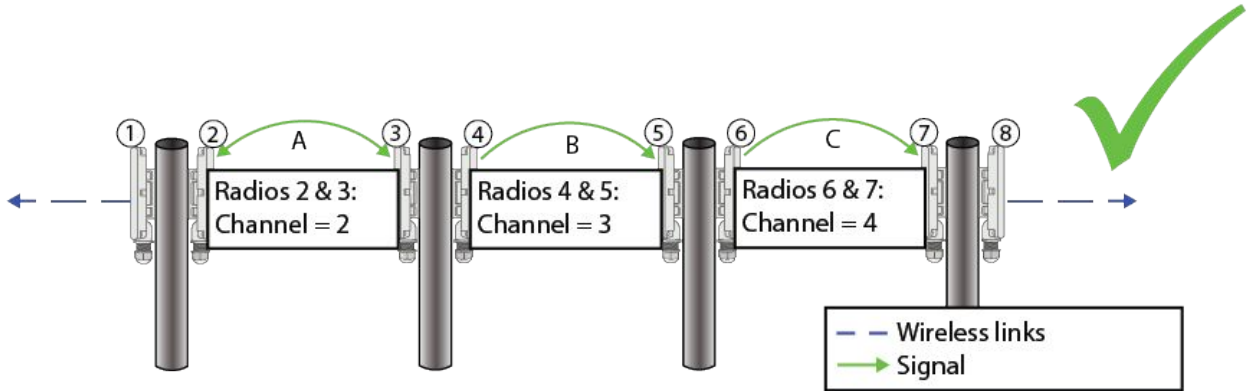

Preparing for installation

The P421 installation instructions include:

- Box contents, mounting options and PoE injector options.
- Functional description.
- Network design information required.
- Bench configuration steps.
- P421 on-site installation steps.

Box contents

- P421 device.
- IP67 cable gland.
- Indoor Power over Ethernet (PoE) injector and power cord.
- QR code card for P421 Quick Start and P421 User Guide.



About the P421

The P421 supports the AltoPlex series for 60 GHz wireless networks and provides wireless coverage for a 90° sector. See the [P421 datasheet](#) for specifications and features. See [Design and Deployment](#) for general design and deployment information, best practices and considerations based on network topology.

The 1.0 Gbps RJ45 port and LED are located at the base of the unit.

The red/green LED on the bottom of the P421 device shows power, connection and activity.

- Red — powering up.
- Flashing red and green — during boot up.
- Flashing green — until at least one wired link and one wireless link is formed.
- Steady green — normal operations with one or more wired and one or more wireless link.

See [LED Indicators](#) for more detail.

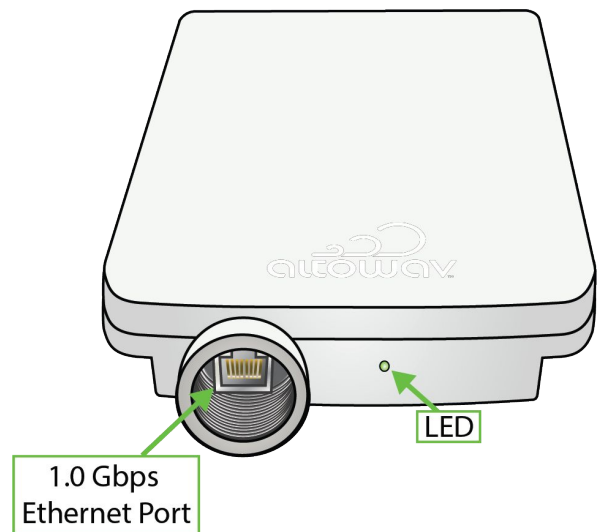

Mounting brackets

Altoway offers two optional mounting brackets. The two mounting brackets can be used together to provide both azimuth and elevation control.

- The Altoway Wall Mount, model number AX-AW3-MT-WALL.
- The AltoPlex Extended Range Pole Mount, model number AX-AW3-MT-EXT.

Altoway Wall Mount

The Altoway Wall Mount, model number AX-AW3-MT-WALL, can be used to securely mount the P421 to a wall or similar flat surface. It can also be used in tandem with the AltoPlex Extended Range Pole Mount to provide both azimuth and elevation control.

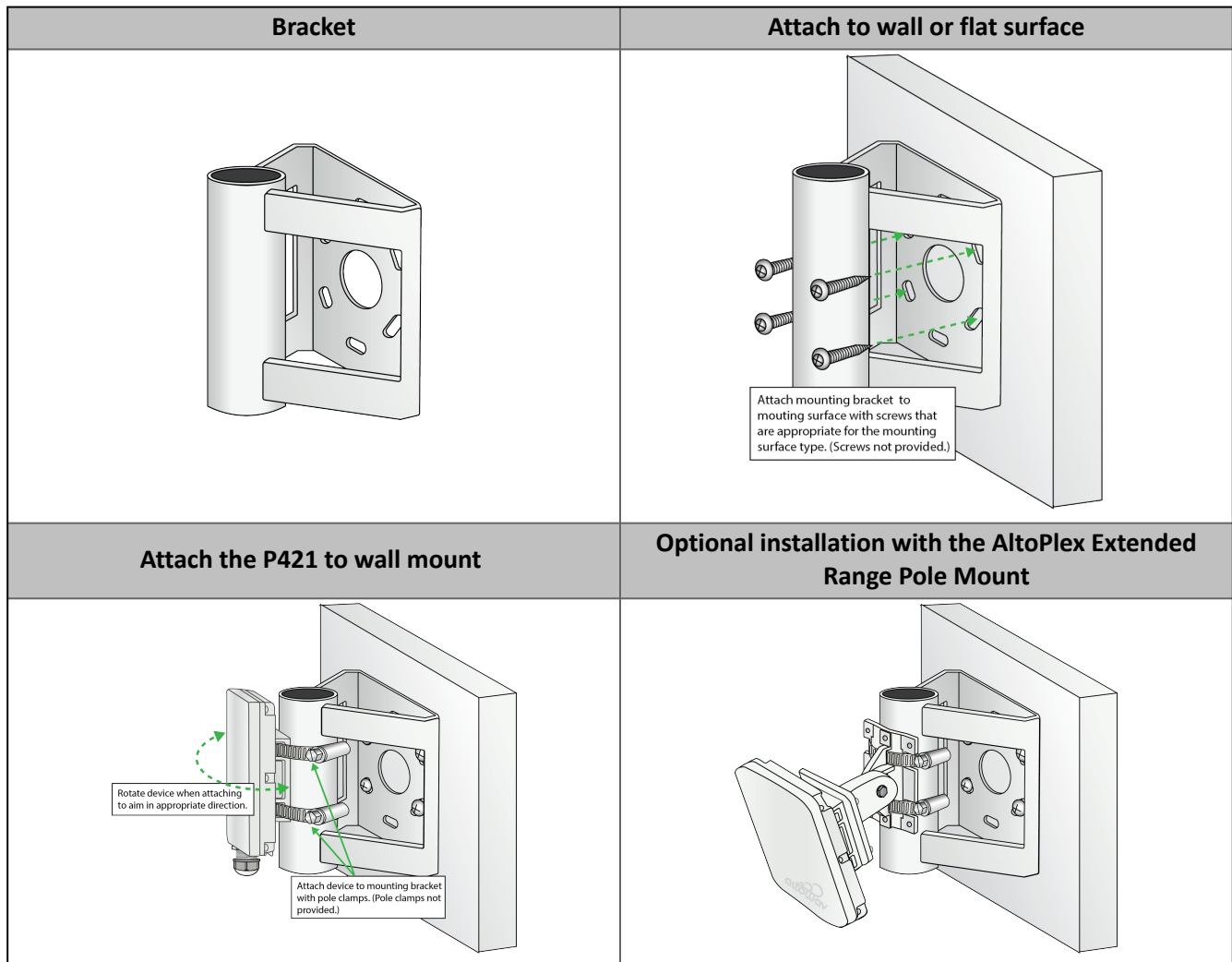

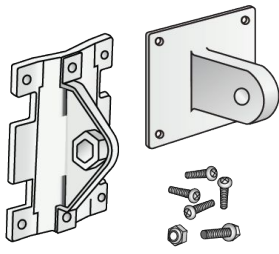
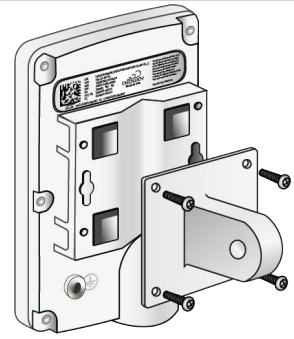
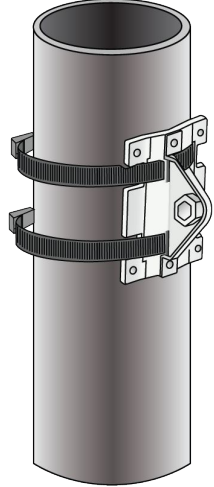
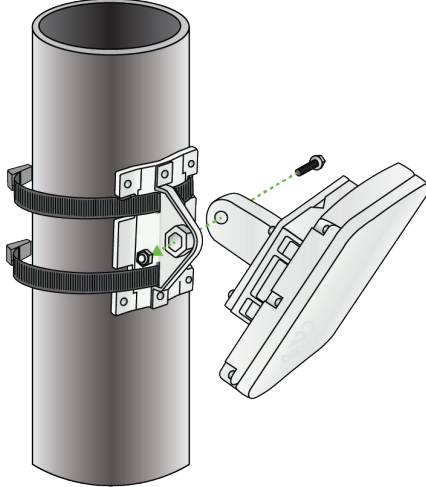
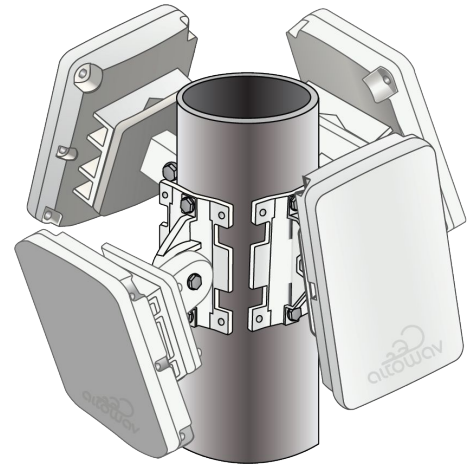
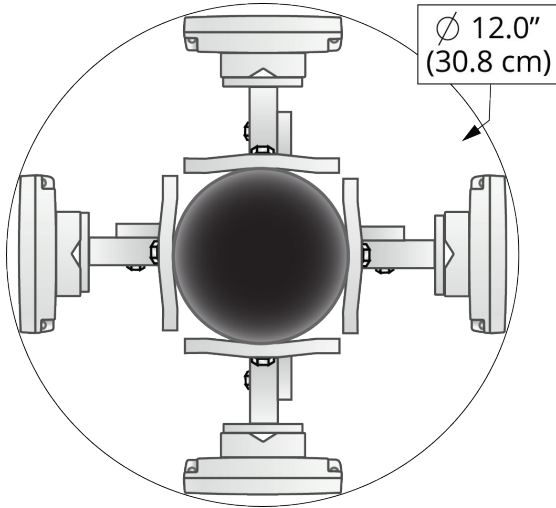

AltoPlex Extended Range Pole Mount

The AltoPlex Extended Range Pole Mount, model number AX-AW3-MT-EXT, enables secure installation and elevation adjustments from +60° to -45°. This model can be used for pole mounting with screws, bolts, or band clamps, and can also be used in tandem with the Altoway Wall Mount, as show above.

Bracket	Attach to the P421
	
Pole mounting with band clamps	
	
360° coverage	Small form factor
	 <p>Ø 12.0" (30.8 cm)</p>

Powering the P421

Indoor and outdoor PoE input options are available to provide power to the P421.

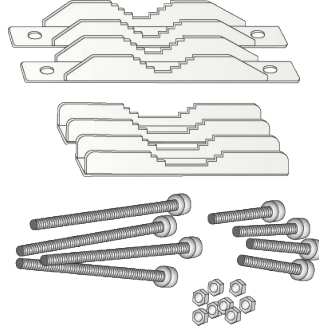
		
<p>30W Indoor PoE Injector Model: AX-P-IN-AT-5G Model: AX-P-IN-AT-5G</p>	<p>Outdoor 2.5GbE 60W PoE switch Model: AX-PSW-OD-4AT-4C25</p>	<p>Outdoor PoE switch mounting brackets Model: AX-PSW-OD-MOUNT</p>

Install the outdoor 2.5GbE 60W PoE switch

These instructions cover the preparation of the **Line AC** terminal and weatherproof installation of cable into the **PoE ports**. Examples of mounting the PoE switch are also provided.

Note: Link Layer Discovery Protocol (LLDP) is required for correct LAN peer identification when using multiple AltoPlex devices at one switch point. The outdoor PoE switch supports LLDP. If another switch is being used, LLDP must be supported and enabled on that switch.

1. Line AC power input port with waterproof cap and gland.
2. Power over Ethernet (PoE) ports with waterproof glands.
3. Mounting holes.
4. Ground.

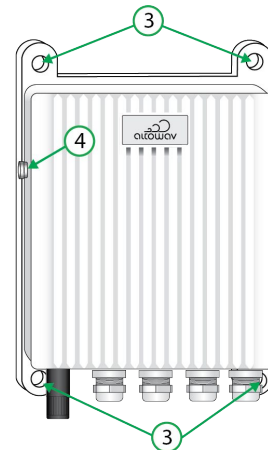
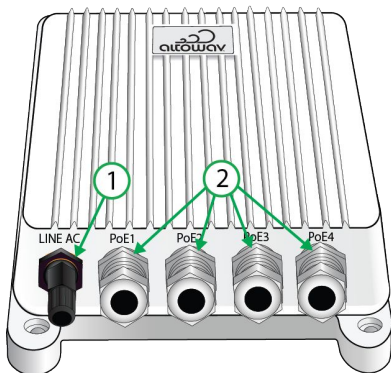

Install AC power

1. Unscrew the waterproof cap and gland from the Line AC power input port.
Temporary pigtail wires indicate correct wire placement, as shown.



2. Disassemble the waterproof cap and gland.



3. Using an SO power cord (3-wire 18AWG):

- A. Strip 25 mm (1 in.) of the cable jacket and 10 mm (3/8 - 1/2 in.) of insulation from each wire.
- B. Insert the prepared cord into the disassembled cap and gland.



4. Using a Phillips-head screwdriver, insert the wires into the correct pin ports one at a time:
 - A. Loosen one screw and remove the temporary pigtail wire.
 - B. Insert the correct wire (live, neutral, or ground) and tighten the screw.
 - C. Repeat for each wire.
 - D. Slide the waterproof gland over the AC input port pins and hand tighten to the housing.
 - E. Hand tighten the cap to the gland.



Install Ethernet cables

1. Unscrew and disassemble the PoE Ethernet end caps and glands from the ports on the PoE switch.
2. Insert an outdoor-rated Cat6 Ethernet cable in the component parts of the PoE Ethernet end caps and glands. You may need to cut a slit in the rubber grommet from top to bottom, to allow inserting the Ethernet cable.

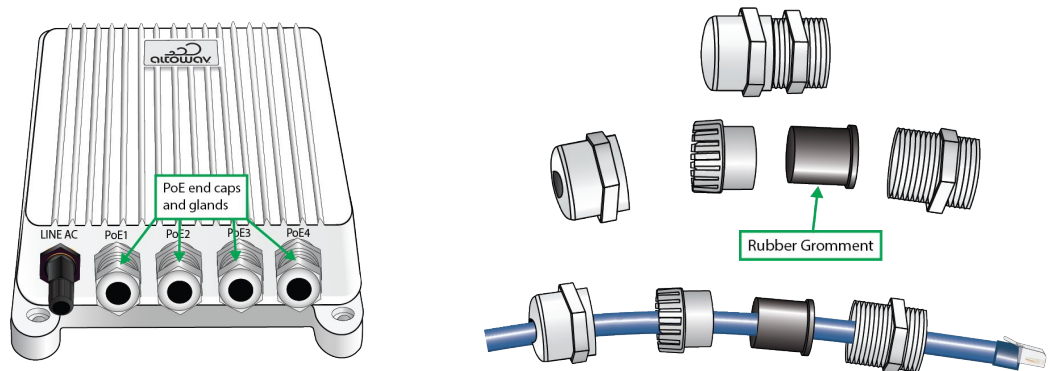

3. Securely plug the RJ45 connector into the RJ45 slot inside a PoE port. Listen for a click to verify a solid connection.
4. Slide all cable gland components up the Cat6 and into the PoE port. Components should self-align and seal adequately.
5. Fasten the steel end caps securely, but do not over tighten. The goal is tight enough to keep water out, without impacting the internal RJ45 connection.
6. Repeat the end cap reassembly for the remaining RJ45 connections.

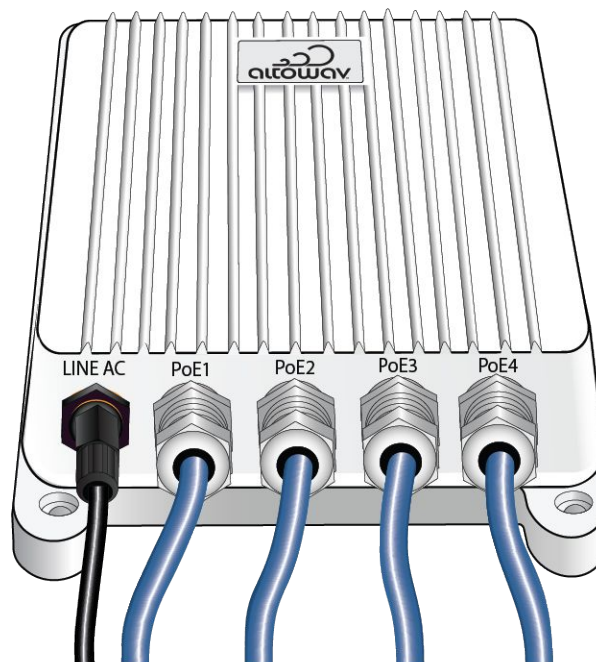

Examples of outdoor PoE switch installation

Metal pole mount

Additional required equipment (not supplied):

- Metal strapping and screws.
- Outdoor electrical faceplate and clamp cable connector.

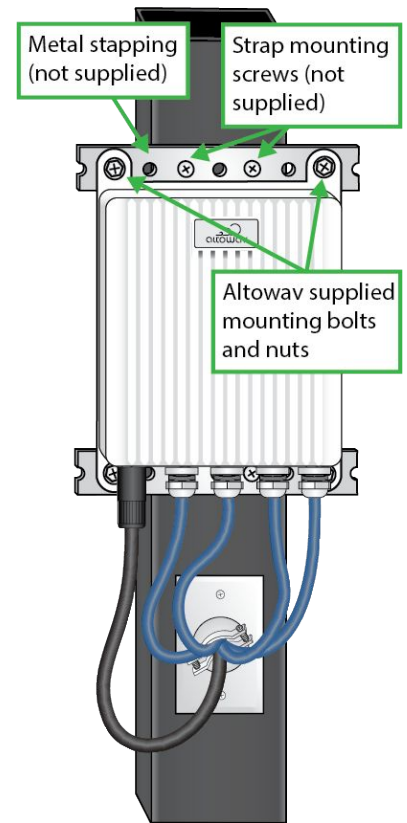

Wood pole with conduit mount

Additional required equipment (not supplied):

- Pole mounting bracket, Altoway part number AX-PSW-OD-MOUNT
- Conduit
- Conduit straps
- Strut channel

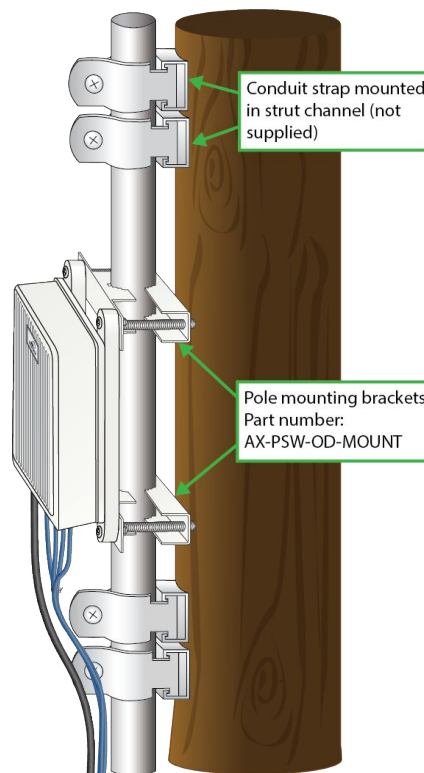

Required network design information

Before installation, a network design should be planned and documented. A detailed network diagram prior to configuration and installation can help avoid costly, time-consuming adjustments after installation. Required information for installation and configuration of the P421 includes:

- The hostname and MAC address of the device, listed as **HN:** and **MA:** on the device label. Scan the QR code on the label for a text string that includes the MAC address.
- The MAC address for this radio's point-to-point partner radio.
- If VLAN will be used, the Management VLAN ID and PVIDs for this network site.
- Installation site information:
 - Planned azimuth for clear LOS between the devices on each end of each wireless link.
 - Any elevation changes for the install mount.
 - **Location/Description** information for configuration per your institution's requirements. Consistent information in these fields can be used by monitoring software, such as the AltoCommand, to identify specific devices in dense topologies.

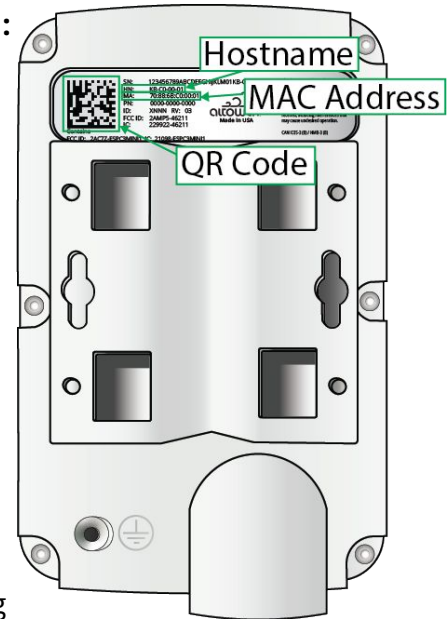

Tip: Adopt standard conventions and practices to help simplify design, installation and reading detailed network diagrams.

- **Boresight:** Position the P421 at an azimuth that makes DN links as close to boresight as possible.
 - Because AltoPlex devices use a wide-angle beam pattern that can scan across a 90° horizontal and +/-20° vertical air space, boresight is not required but will create the strongest link.
- **Distance:** The shorter a link, the better the performance.

Connecting to the P421

By default, AltoPlex radios use dynamic IP address assignment and, beginning with release 3.6.0, have a factory default fallback static IP address of 192.168.0.1.

Additionally:

- Radios can be configured to use a static IP address, rather than dynamic IP address assignment. This will override the fallback IP unless the radio is [factory reset](#). After a factory reset, it will return to default behavior.
- Radios upgraded to release 3.6.0 that have not been factory reset will have a factory default fallback IP address of 192.168.0.51, unless they have a configured static IP address that overrides the default address. After a factory reset, they will have the default behavior.
- Radios at a release earlier than 3.6.0 have a unique factory default IP address that is printed on the label affixed to the front of the radio at manufacturing time.

Note: You can determine if your radio was manufactured before release 3.6.0 based on the IP address printed on the label on the front of the radio:

- If the radio was manufactured before the release of 3.6.0, the IP address on the label will be a unique IP address.
- If the radio was manufactured after the release of 3.6.0, it will either not have an IP address on the label, or the IP address will be 192.168.0.1.

Because AltoPlex radios participate in multicast DNS (mDNS), computers that support mDNS and are on the same subnet as the radio can connect to the radio by using its hostname. In general, this should work regardless of whether the radio is configured to use dynamic or static addressing, or if it is using the fallback default IP.

For example, if your radio's hostname is KB-C7-00-01 and your computer is on the same subnet as the radio, you can access the WebUI by typing **https://KB-C7-00-01** (or **https://KB-C7-00-01.local**) into your browser's URL address bar:

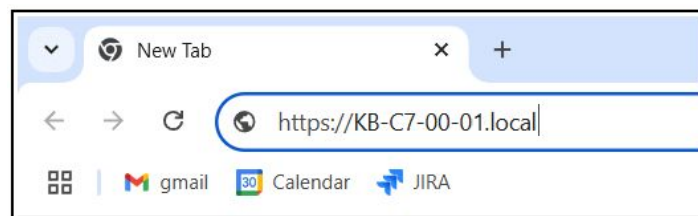

Use the factory default fall-back IP address to connect to the radio

This section applies to radios with firmware version 3.6.0 or newer. Radios with older firmware have a unique fallback link local IP address that was provided on a printed label when the device was manufactured. For devices originally manufactured with a software version prior to 3.6.0 and then upgraded to release 3.6.0 or newer, the default IP address will depend on whether the device has been factory reset since the upgrade:

- If the device has not been factory reset, the default IP address is 192.168.0.51.
- If the device has been factory reset, the default IP address is 192.168.0.1.

To connect to an AltoPlex radio by using its default fallback IP address:

1. Configure your computer to be a member of the 192.168.0.x subnet.

For example, on Windows 11:

- A. Click the **Windows** icon.
- B. Click **Settings**.
- C. Click **Network & internet**.
- D. Click **Ethernet**.
- E. For **IP assignment**, click **Edit**.
- F. Select **Manual**.
- G. Click to toggle on **IPv4**.
- H. For **IP address**, type an address in the 192.168.0.x subnet (for example, **192.168.0.2**).
- I. For **Subnet mask**, type **255.255.255.0**.
- J. Click **Save**.

2. Next, either:

- Plug your computer's Ethernet connection into the **LAN** port of a PoE injector that is connected to the radio.

Tip: The LAN port is sometimes labeled as the **Data out** port, the **Out** port, or something similar.

- Plug both your computer and the radio into a PoE switch.

Tip: To access the radio by using the default IP address, make sure that the switch is not connected to the backhaul network or that the backhaul network does not have a DHCP server running on it.

3. Access the radio's WebUI by entering either the hostname (for example, **https://KB-C7-00-01**) or the default IP address (**https://192.168.0.1**) in the address bar of a web browser.

Note: If a radio has a configured static IP address that is different than the default address, the configured IP address must be used to access the radio.

4. A warning message may indicate that the self-signed certificate used by the device is not recognized by the browser. Instructions to clear the message vary depending on the browser. For example, in Chrome:
 - A. Click **Advanced**.
 - B. Click **Proceed to...**

The WebUI will open with the [Status tab](#) displayed.

Determine the IP address of a radio by using mDNS

If you configure a radio to use a static IP address and subsequently do not remember the IP address, you can use mDNS commands to determine the radio's IP address.

Note: This requires that your computer supports mDNS and is on the same subnet as the radio.

- Windows Powershell:
`Resolve-DnsName <hostname>`
- MacOS:
`dns-sd -G v4v6 <hostname>`
- Linux:
`avahi-resolve-host-name -4 <hostname>.local`

where <hostname> is the hostname of the AltoPlex radio (KB-XX-XX-XX).

Access the radio by using the management Wi-Fi access point

AltoPlex radios also provide a mechanism to access all radios through a management Wi-Fi access point, which is enabled by default but can be disabled. See [Wi-Fi connection to a P421](#) for more information.

Installation

Installation tips:

- When included in a bridge kit, the P421s are preconfigured to automatically connect to each other when installed.
 - Install the P421 on the pole or wall with no obstructions above the unit to allow for GPS synchronization.
 - Maintain **clear line of sight (LOS)** at the front of the P421 so that links to other radios can be formed. Best performance is achieved with boresight alignment between P421 wireless devices, so this is recommended for DN to DN links. Because AltoPlex devices use a wide-angle beam pattern that can scan across a 90° horizontal and +/-20° vertical air space, boresight is not required but will create the strongest link.
 - **Power source:** For outdoor use, the 4 Port 2.5G PoE switch (AltoWay Model AX-PSW-OD-4AT-4C25) is recommended. This outdoor PoE switch can provide power for up to four connected devices. If weatherproof enclosure is available on site and power for only one device is required, the optional AX-P-IN-AT-5G (30 W indoor PoE injector) can be used.
- If a customer-supplied switch is used:** To take advantage of the [LL discovery feature](#), the switch should support LLDP and it should be enabled. Also be aware that managed switches with Rapid Spanning Tree Protocol (RSTP) enabled increase the hop count for RSTP. See [Network tab — Spanning Tree Protocol configuration](#) for details about configuring AltoPlex devices for RSTP.
- When adjustments to positioning or aiming the P421 are done after the device is linked to other devices, power cycle the unit. To power cycle, simply disconnect the device from power and reconnect it.

Installation procedure

Note: A clear line of sight must be maintained for an optimal wireless link, preferably at boresight for DN links.

1. Install the ground wire, if required by code, at the installation location. Connect the other end of the ground wire to nearby good earth. The ground screw on AltoPlex devices is a #6-32 5/16th inch Phillips head screw.

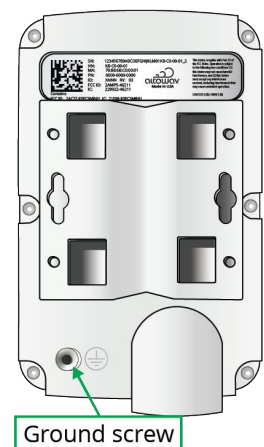

2. Install an outdoor-rated Ethernet cable through the provided cable gland and into the port on the P421 device:
 - A. Unscrew and deconstruct the components of the gland.

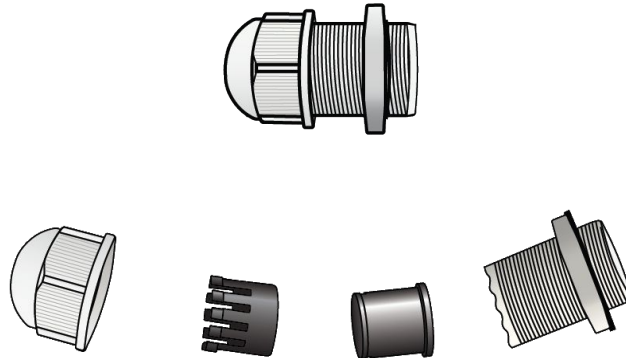

- B. Insert an outdoor-rated Cat5e (minimum) cable in the gland as shown.

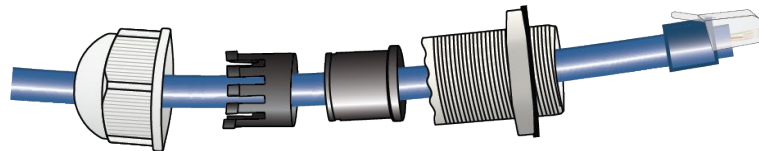

- C. Secure the components of the gland and attach the Cat5e cable to the device's RJ45 port and attach the gland to the device. Do not overtighten.
3. Mount the device to a wall or pole at the installation location with the mounting bracket (see [Mounting bracket](#)). Ensure a clear line of sight to the connecting distribution node and no obstructions to GPS above the unit. Orient the P421 according to the planned azimuth and elevation.
4. PoE options available from Altoway include:
 - Outdoor PoE switch, part number AX-PSWOD-4AT-4C25.
 - Outdoor PoE switch mounting bracket, part number AX-PSW-OD-MOUNT.
5. Connect the other end of the Cat5e cable to the PoE port on the PoE injector or to a PoE switch.

Note: The supplied PoE injector is an indoor unit so it requires a weatherproof box for outdoor installation.

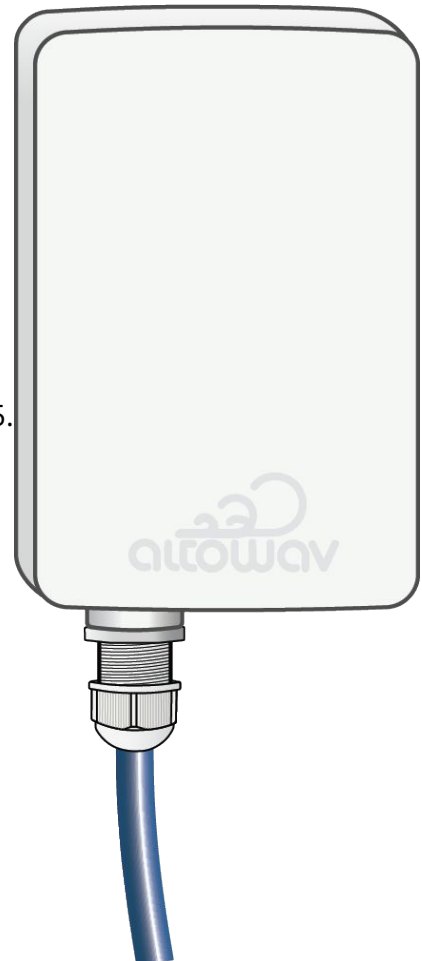

6. Verify that the device powers up. (LED is red during boot-up and then flashing green.)
7. If other P421s will be installed at the same site (for example, on the same pole), install them according to the design plan. Devices connected through a PoE switch at the same site will become LAN peers via their wired connection through the PoE switch.
8. Move to the next site and mount the P421 that will link to the first P421.
 - A. Mount the connecting device.
 - B. Power up.
 - C. Perform DN link auto-configuration.



Note: If DN link auto-configuration isn't used, all devices should be configured prior to mounting the devices.

9. For multi-link [daisy-chain](#) or [ring](#) topologies, install the remaining P421 devices according to the detailed network plan.
 - A. If DN link auto-configuration is being used in the field, configure each DN link in the field as the devices are installed.

Note: If the P421 is repositioned or re-aimed after DN connections are made, rebeamform the link by resetting the **DN responder** on one end of the link, rebooting, or power cycling the unit. Resetting the responder is the least disruptive method to an operational network.
 - B. Verify that each P421 is connected to its linked pair . This sample of the **Wireless** table on the [Status tab](#) shows the P421 connected to another P421 (KB-C0-00-01).

Wireless												
Radio	MAC Address	Description	Chan	DN/ CN	Peer- Name	Link State	SNR	RSSI	TX MCS	TX Power Index	TX angles	RX angles
0	70:88:6b:c7:00:01	Techpubs radio 0	1	DN	KB-C7-00-01	UP 20:34:53	18/15	-56/-59	9/9	6/6	7/0 -3.5/7.5	8.75/0 -3.5/7.5

- C. **Check signal quality.** For example, a P421-P421 link should have an RSSI of greater than -65. Expected MCS for a P421-P421 link is 9 for up to 250 m, and 12 for up to 150 m with significant traffic.

Configuration

When included in a bridge kit, the P421s are preconfigured to automatically connect to each other when installed. No further configuration is required. Additional configuration, such as setting the radio's description and location, as well as specific networking configuration for your location, can be performed. See [Configuration via the WebUI](#).

Note: If you factory reset one of the radios in a bridged pair, the bridge between the radios will no longer work. Follow the instructions for [Configure a replacement radio](#), below, to reconfigure the devices to form a bridged connection.

Configure a replacement radio

If your radio is a replacement unit, after you replace the defective radio, the steps required to establish a link to the existing radio vary depending on which radio in the link is being replaced.

Note: These steps also apply when a radio in a bridged pair has been factory reset, in which case it will behave like a replacement radio.

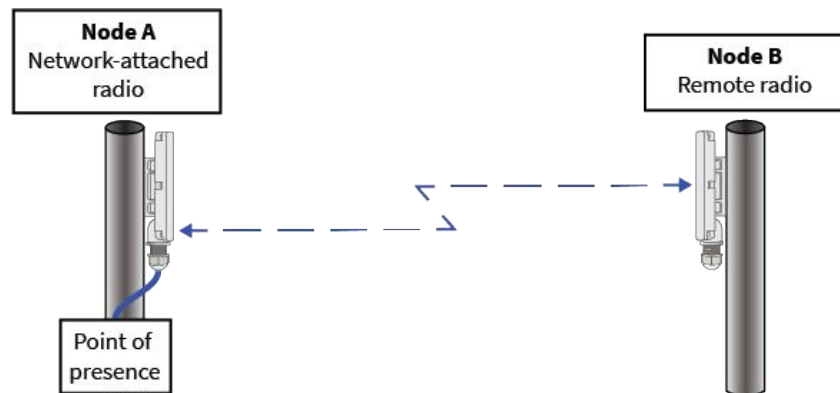

If the radio being replaced is the network-attached device (node A in the above diagram):

1. Connect to the remote radio (node B) by using its diagnostic Wi-Fi access point or a wired connection.

Note: If the radio cannot be accessed by either Wi-Fi or a wired connection, physical access to the radio to perform a hard factory reset is required.

2. Remove the existing link to the defective radio and reboot node B.
3. On the replacement radio (node A), use the DN link auto-configuration feature to establish a link to the existing remote radio (node B).

See the following procedures, below, for instructions.

If the radio being replaced is the remote device (Node B in the above diagram):

- On the existing radio (Node A), remove the link to the defective radio and use the DN link auto-configuration feature to establish a new link. See the following procedures, below, for instructions.

Remove link to previous radio

Note: When included in a bridge kit, the P421s are preconfigured to automatically connect to each other when installed. This procedure is for a replacement unit only.

If your radio is a replacement unit, and the radio being replaced is the network-attached device (node A in the above diagram), you must be able to access the remote device (node B). To connect to the remote device, you must have wired or Wi-Fi access to the radio. If you cannot access the radio by using Wi-Fi or a wired connection, physical access to the radio is required to perform a hard factory reset.

1. Access the WebUI of the P421. In your browser's address bar, type:

https://hostname

where *hostname* is the hostname (KB-XX-XX-XX) or IP address of the radio. See [Connecting to the P421](#) for more information.

2. Click the **login** link in the WebUI header to log in as administrator. The default password is **admin**.

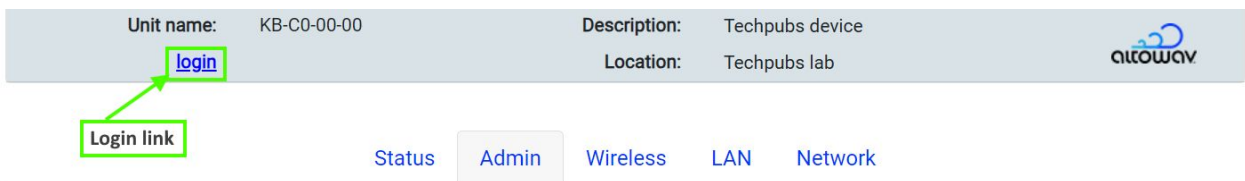

3. Click the **Wireless** tab.
4. Delete the MAC address of the defective radio from the **Radio 0 DN responder** field.
5. Click **Submit Changes**.

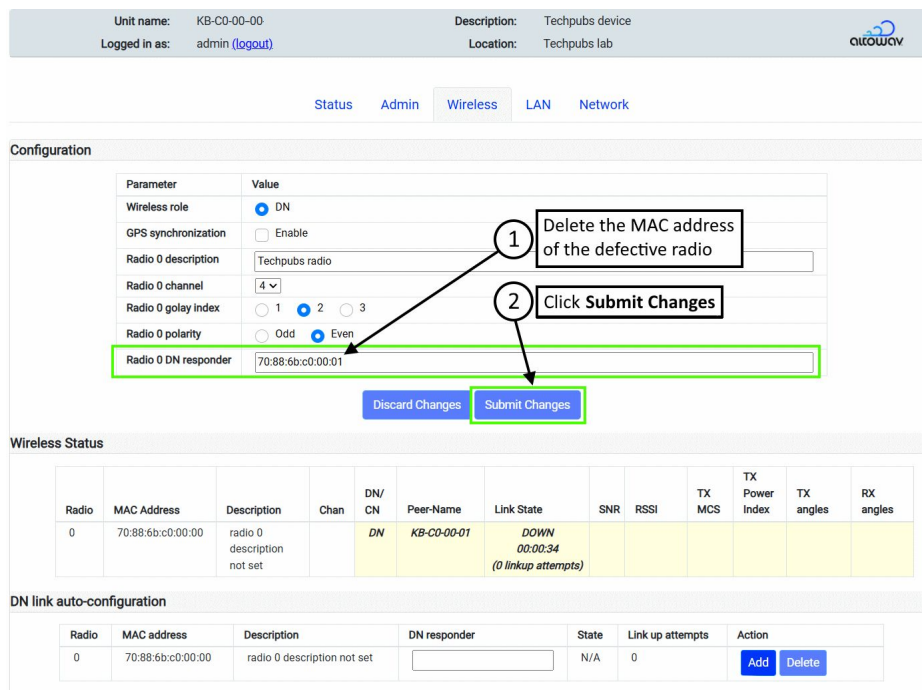

6. If this procedure is being performed:
 - On the network-attached radio (Node A in the above diagram), proceed to step 4 in the [DN link auto-configuration](#) section, below.
 - On the remote radio (Node B in the above diagram):
 - a. Click the **Admin** tab.
 - b. Click **Reboot Unit**.

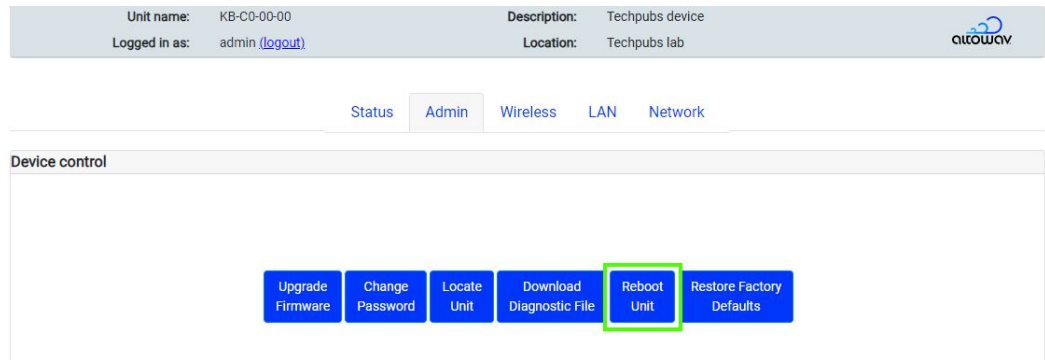

- c. Proceed to the [DN link auto-configuration](#) section, below.

DN link auto-configuration

1. Access the WebUI of the P421. In your browser's address bar, type:

<https://hostname>

where *hostname* is the hostname (KB-XX-XX-XX) or IP address of the radio. See [Connecting to the P421](#) for more information.

2. Click the **login** link in the WebUI header to log in as administrator. The default password is **admin**.

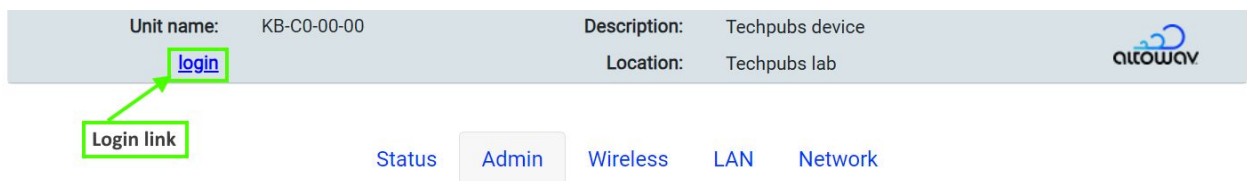

3. Click the **Wireless** tab.
4. In the **DN link auto-configuration** section, type the MAC address of the **DN responder**.
5. Click **Add**.

Unit name: KB-C0-00-00
Logged in as: admin (logout)
Description: Techpubs device
Location: Techpubs lab

Status Admin Wireless LAN Network

Configuration

Parameter	Value
Wireless role	<input checked="" type="radio"/> DN
GPS synchronization	<input type="checkbox"/> Enable
Radio 0 description	<input type="text" value="Techpubs radio"/>
Radio 0 channel	<input type="text" value="4"/>
Radio 0 golay index	<input type="radio"/> 1 <input checked="" type="radio"/> 2 <input type="radio"/> 3
Radio 0 polarity	<input type="radio"/> Odd <input checked="" type="radio"/> Even
Radio 0 DN responder	<input type="text"/>

Wireless Status

Radio	MAC Address	Description	Chan	DN/ CN	Peer-Name	Link State	SNR	TX	SS
0	70:88:6b:c0:00:00	radio 0 description not set							

DN link auto-configuration

Radio	MAC address	Description	DN responder	State	Link up attempts	Action
0	70:88:6b:c0:00:00	radio 0 description not set	70:88:6b:c0:00:02	N/A	0	<input type="button" value="Add"/> <input type="button" value="Delete"/>

3 Type the MAC address of the remote radio

4 Click Add

After the connection between the devices has been initialized, perform additional configuration as necessary. See [Configuration via the WebUI](#).

Page 32

Configure a connection to an AltoCommand server

Beginning with release 3.9.1, AltoPlex radios can be configured to connect to an AltoCommand server. The AltoCommand server may be cloud-based, or may reside on the local network. This feature requires AltoCommand version 4.0.

After the connection to the AltoCommand server has been configured on the AltoPlex radio, the radio sends an approval request to the server. A user on the AltoCommand server must approve the request, which will open a reverse tunnel for communication between the server and the radio.

To configure the connection to an AltoCommand server:

1. Access the WebUI of the P421. In your browser's address bar, type:

https://hostname

where *hostname* is the hostname (KB-XX-XX-XX) or IP address of the radio. See [Connecting to the P421](#) for more information.

2. Click the **login** link in the WebUI header to log in as administrator. The default password is **admin**.

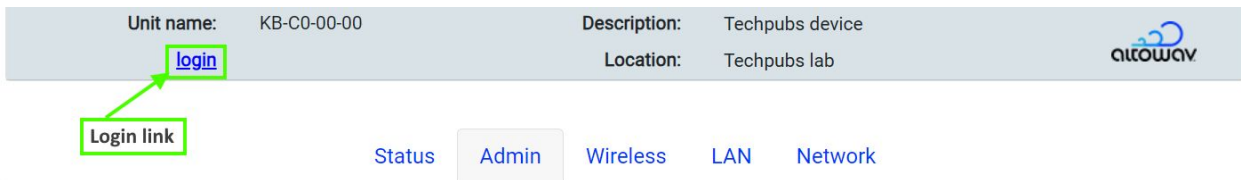

3. Click the **Admin** tab.
4. In the **Configuration** section, for **AltoCommand server**, type the fully-qualified domain name or IP address of the AltoCommand server.
5. Click **Save Changes**.

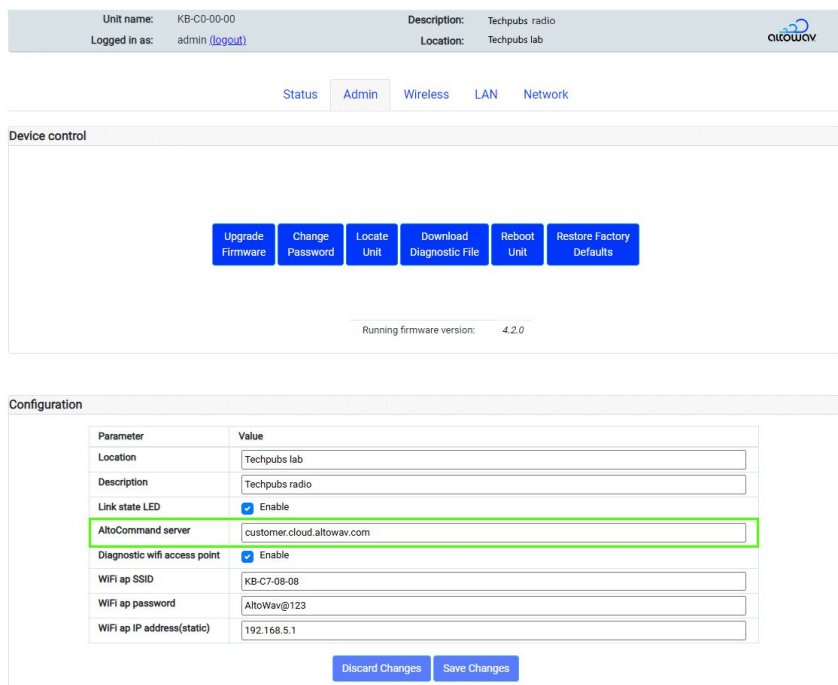

View the status of the connection to the AltoCommand server

To view the status of the connection to the AltoCommand server:

1. Access the WebUI of the P421. In your browser's address bar, type:

`https://hostname`

where *hostname* is the hostname (KB-XX-XX-XX) or IP address of the radio. See [Connecting to the P421](#) for more information.

2. The **Device Information** section of the **Status** tab displays the current status of the **AltoCommand connection**.

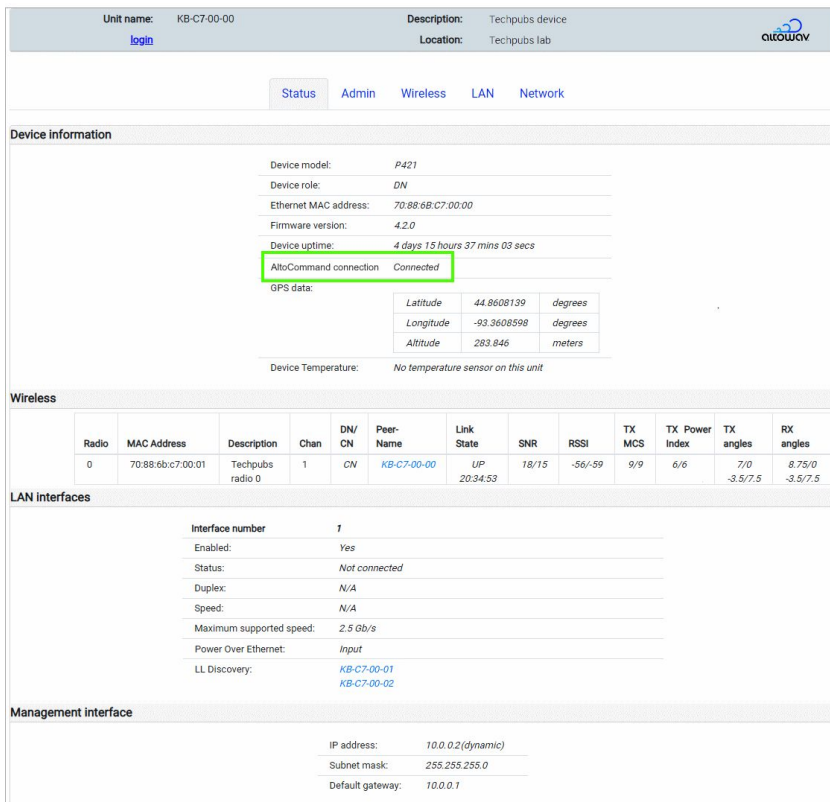

The screenshot shows the WebUI interface for a P421 device. At the top, it displays 'Unit name: KB-C7-00-00' and 'Description: Techpubs device'. Below this, there are tabs for 'Status', 'Admin', 'Wireless', 'LAN', and 'Network'. The 'Status' tab is selected, and the 'Device information' section is expanded. In this section, the 'AltoCommand connection' is highlighted with a green box and shows a status of 'Connected'. Other fields include 'Device model: P421', 'Device role: DN', 'Ethernet MAC address: 70:88:6b:c7:00:00', 'Firmware version: 4.2.0', and 'Device uptime: 4 days 15 hours 37 mins 03 secs'. A table for 'GPS data' shows Latitude: 44.8608139 degrees, Longitude: -93.3608598 degrees, and Altitude: 283.846 meters. Below this, the 'Wireless' section contains a table with columns for Radio, MAC Address, Description, Chan, DN/CN, Peer-Name, Link State, SNR, RSSI, TX MCS, TX Power Index, TX angles, and RX angles. The table shows one entry for radio 0 with a 'UP' link state. The 'LAN interfaces' section shows interface 1 is 'Not connected'. The 'Management interface' section shows IP address: 10.0.0.2 (dynamic), Subnet mask: 255.255.255.0, and Default gateway: 10.0.0.1.

Displayed values are:

- **Not configured** — The AltoCommand server has not been configured on the radio.
- **Disconnected** — The AltoCommand server has been configured on the radio but is not connected. Possible issues include an incorrect URL for the server, network access issues, etc.
- **Pending** — The AltoCommand server has been configured and successfully accessed, and the radio is waiting for the server to accept the connection.
- **Connected** — The radio is successfully connected to the configured AltoCommand server.

Configuration via the WebUI

The P421 can be configured through the WebUI. Access the WebUI by using one of the following methods:

- In your browser's address bar, type:

https://hostname

where *hostname* is the hostname (KB-XX-XX-XX) or IP address of the radio. See [Connecting to the P421](#) for more information.

- Link from the Wireless table of a connected device's WebUI by clicking the name of the device to configure in the **Peer Name** column of that table.

MAC Address	State	Channel	Remote MAC	Peer-Name	SNR Local/Remote	RSSI Local/Remote	TX MCS Local/Remote	TX Power Index Local/Remote
70:88:6b:c0:00:03	UP	4	70:88:6b:c0:00:04	KB-C0-00-04	11/12	-63/-62	9/9	12/7

- Use the device's [management Wi-Fi](#).
- If using the AltoCommand, access the WebUI from the **Devices** page by clicking  at the end of a device's row and clicking **Connect to Device**.

Some common tasks at the WebUI:

- View information about the device, such as the firmware version data-keyref="management-UI">AltoCommand server status, and wireless connections, on the [Status tab](#). You can also click on a **Peer-Name** to access the WebUI for a connected device.
- On the [Admin tab](#):
 - Configure the location of your AltoCommand server. (Requires AltoCommand version 4.0).
 - [Upgrade firmware](#).
 - [Change the admin password](#).
 - Locate the radio.
 - [Download a diagnostic file](#).
 - [Reboot](#).
 - [Restore Factory Defaults](#).
 - Set the **Location** or **Description** per your network design plan.
 - [Configure diagnostic Wi-Fi settings](#).
- On the [Wireless tab](#), for point-to-point bridge kits, the link to it's pair is already configured. If you are replacing one of the radios, follow the instructions in [Configure a replacement radio](#).
- On the [LAN tab](#), configure [MAC filtering](#).

- On the [Network tab](#), configuration various networking features, such as VLANs, Spanning Tree protocol, and the management interface.

The header of the WebUI shows the **Unit name** of the P421 (also called the hostname), **Description** and **Location**, as well as offering a **login** link.



Tip: The header background changes from gray to yellow when a unit is unreachable.



Status tab

The **Status** tab shows a summary of information about the unit, its wireless and LAN connections, and interface information.

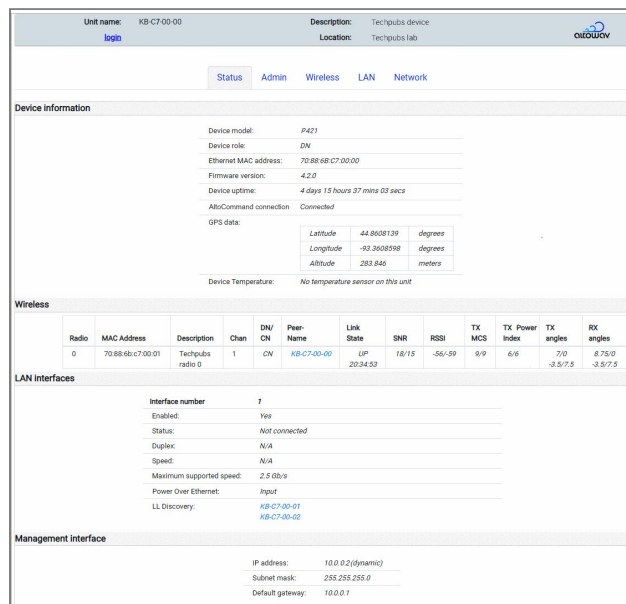

Status tab — Device Information section

This section displays:

- The Device model name (P421).
- The Device role. For point-to-point devices, this is always **DN**.
- The MAC address.
- The current firmware version.

It is generally recommended that all devices in the network use the same firmware version. See [Upgrading Firmware](#) for information about upgrading the radio's firmware.

- Device uptime.
- AltoCommand server status. (This feature requires AltoCommand version 4.0.)

Displayed values are:

- **Not configured** — The AltoCommand server has not been configured on the radio.
 - **Disconnected** — The AltoCommand server has been configured on the radio but is not connected. Possible issues include an incorrect URL for the server, network access issues, etc.
 - **Pending** — The AltoCommand server has been configured and successfully accessed, and the radio is waiting for the server to accept the connection.
 - **Connected** — The radio is successfully connected to the configured AltoCommand server.
- GPS data.
 - Device temperature.

Status tab — Wireless section

The table in this area shows wireless link status for the unit. Use the horizontal scroll bar to view all values.

Wireless													
Radio	MAC Address	Description	Chan	DN/ CN	Peer- Name	Link State	SNR	RSSI	TX MCS	TX Power Index	TX angles	RX angles	
0	70:88:6b:c7:00:01	Techpubs radio 0	1	DN	KB-C7-00-01	UP 20:34:53	18/15	-56/-59	9/9	6/6	7/0 -3.5/7.5	8.75/0 -3.5/7.5	

- **Link State** lists the state of the link and the length of time that the link has been up or down. Values are:
 - **Up** — The link is functioning normally.
 - **Up but blocked** — The link is formed but is being blocked by [Spanning Tree Protocol](#).
 - **Down** — The link is down. Includes the number of unsuccessful linkup attempts.
- **SNR, RSSI, TX MCS, TX Power Index, TX angles, and RX angles** show values for both ends of the link, in local/remote order.
- **TX angles** and **RX angles** refer to the beam angle when looking from behind the radio towards the linked peer.

- A positive value refers to the beam angle to the right of boresight.
- A negative value refers to the beam angle to the left of boresight.

Tip: The hostnames listed under **Peer-Name** are clickable links and will open the radio's WebUI in a new browser tab.

Status tab — LAN interfaces section

This section shows information for the LAN interface (Port 1 for the P421), including whether the port is enabled, its status (**Connected** or **Not connected**), duplex mode, speed, maximum supported speed, and PoE mode.

If the device's Ethernet port is connected via a switch to other AltoPlex devices, the hostnames of connected devices will be included in the **LL Discovery** field. Clicking a device's hostname in the **LL Discovery** field will open the WebUI for that device. This is useful to determine which devices are co-located (for example, devices that are installed on the same pole).

Note: **LL Discovery** requires that the devices are connected by an unmanaged switch, or a managed switch that is configured to forward LLDP packet information.

Status tab — Management interface

This section lists the **IP address**, **Subnet mask** and **Default gateway** of the radio's management interface. The IP address field also displays whether the radio is configured to have a dynamic IP address assigned by an upstream DHCP server, or a static IP address. See [Management Network Interface Configuration](#) for more information.

Admin tab

Unauthenticated users can view read-only information about the device in the WebUI. To make changes to the configuration, you must be logged in as an administrator.

Click the **login** link in the WebUI header to log in as administrator. The default password is **admin**.

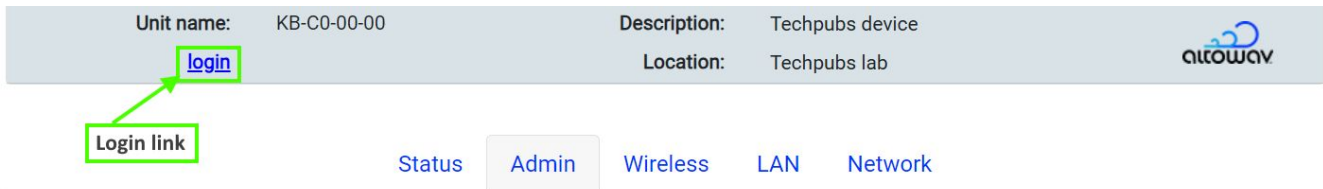

The **Admin** tab has two sections: **Device control** and **Configuration**.

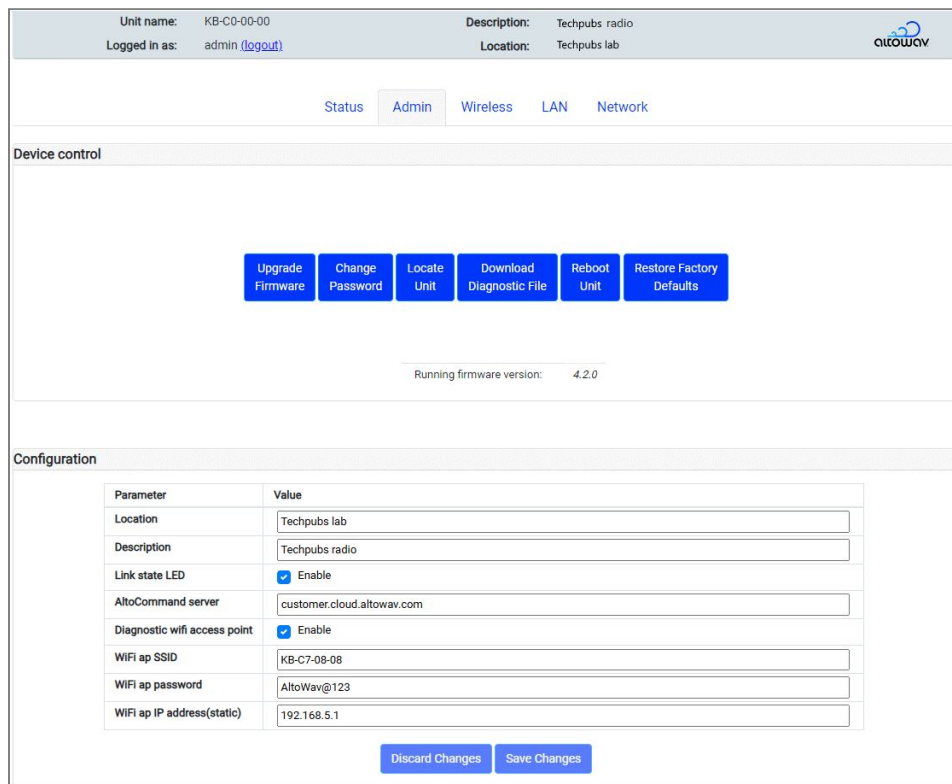

Admin tab — Device control section

This section lists the firmware version on this device. This section also offers controls for the following tasks:

Upgrade Firmware — Updates the device firmware with the file you upload. Click the **Upgrade Firmware** button and browse to and upload the firmware upgrade file. Then click **Start Upgrade**. The device will reboot as part of the upgrade process. For more detailed steps see [Upgrade firmware](#).

Tip: The AltoCommand management interface also offers a convenient way to review firmware version compliance for all AltoPlex devices in your network, and upgrade them from the Devices list. See the [AltoCommand User Guide](#) for more information.

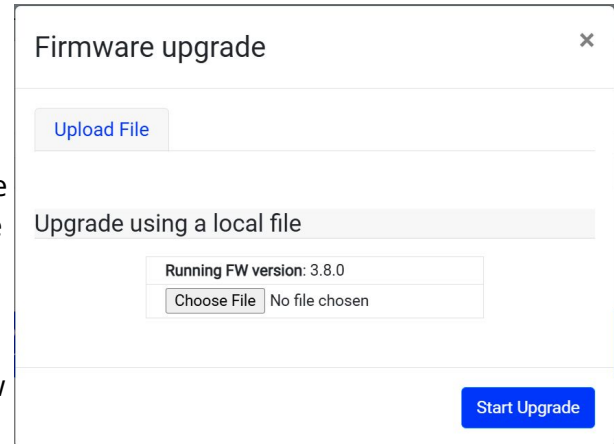

Change Password — Use this button to change the password for the admin of the P421. See [Change a device password](#) for instructions.

Locate Unit — Click this button to put the unit into locate mode. In locate mode, the device flashes the LED in a specific sequence so that field personnel can identify the unit. The LED sequence is: LED flashes red and green.

Download Diagnostic File — Automatically downloads a detailed diagnostic text file for the device. The file contains detailed information about the device and its status at the time of the download. The file name includes the hostname, the date and time. For example, a file named KB-C7-00-01_diag_2025-12-04-14-43-32.txt, means this is the diagnostic text file for the device KB-C7-00-01, created at 2:43:32 pm (UTC) on December 4, 2025. See [Download a Diagnostic File](#) for instructions.

Reboot Unit — Restarts the unit remotely. See [Reboot](#) for instructions.

Restore Factory Defaults — Restores all device configuration to factory defaults. If the unit is unreachable and cannot be reset with this button, it may require a hard factory reset. See the [Factory Reset](#) topic for instructions.

Note: Factory reset returns the unit's password to the default: **admin**. Since the IP assignment uses DHCP by default, the factory reset is not likely to affect the IP address of the device, unless it has been configured to use a static IP address.

Admin tab — Configuration section

This section includes the following settings:

Location — Use this field to describe the physical location where the device is installed. Allows up to 130 characters.

Description — Use this field to provide a description of the device. This may include orientation, function, role or other information about the device. The AltoCommand web-based management tool can automatically use this field as a Switch point tag, when populating the network map, so similar but unique descriptions are recommended. Allows up to 130 characters.

Link state LED — Enables or disables the LED for displaying the node status. See [LED indicators](#).

AltoCommand server — Configures the radio to connect to the specified AltoCommand server. See [Configure the connection to an AltoCommand server](#) for more information.

Diagnostic wifi access point — Enables / disables Wi-Fi access for the unit. Default: **Enable**. See [Wi-Fi Connection](#) for when and how to use the Diagnostic Wi-Fi access point.

Note: Disabling this setting turns off the Wi-Fi access point completely, (not just the Wi-Fi user interface). The device will not be seen by a Wi-Fi search when this setting is disabled.

WiFi ap SSID — Sets the SSID for the diagnostic Wi-Fi access. The SSID defaults to the device's Host Name (KB-XX-XX-XX). Allows up to 32 characters.

WiFi ap password — Sets the password for the diagnostic Wi-Fi access. Default setting: AltoWav@123. Allows between 8 and 63 characters.

WiFi ap IP address (static) — Sets a static IP address for diagnostic Wi-Fi access. Default setting: 192.168.5.1.

Wireless tab

The Wireless tab includes configuration of the device's wireless role, a GPS synchronization checkbox, radio description, channel, Golay index, polarity, and DN responder. You can also change the 60 GHz airlink SSID and password from the Wireless tab. The Wireless status table is also included on this tab, enabling you to view the state of RF links, verify connections and browse to peers, as needed.

Tip: After clicking **Submit Changes**, stay on this tab until the links reset and the Wireless status table updates. This ensures that settings and links are complete before more changes are made.

Unit name: KB-C7-00-00
Logged in as: admin (logout)

Description: Techpubs device
Location: Techpubs lab



Status Admin Wireless LAN Network

Configuration

Parameter	Value
Wireless role	<input checked="" type="radio"/> DN
GPS synchronization	<input type="checkbox"/> Enable
Radio 0 description	<input type="text" value="Techpubs radio"/>
Radio 0 channel	<input type="text" value="2"/>
Radio 0 golay index	<input checked="" type="radio"/> 1 <input type="radio"/> 2 <input type="radio"/> 3
Radio 0 polarity	<input checked="" type="radio"/> Odd <input type="radio"/> Even
Radio 0 DN responder	<input type="text"/>
Radio 0 CN responder	<input type="text" value="KB-C7-08-3E"/> <input type="button" value="X"/> <input type="text"/> <input type="button" value="+"/>

Wireless Status

Radio	MAC Address	Description	Chan	DN/ CN	Peer-Name	Link State	SNR	RSSI	TX MCS	TX Power Index	TX angles	RX angles
0	70:88:6b:c7:00:00	Techpubs radio										

DN link auto-configuration

Radio	MAC address	Description	DN responder	State	Link up attempts	Action
0	70:88:6b:c7:00:00	Techpubs radio	<input type="text"/>	N/A	0	<input type="button" value="Add"/> <input type="button" value="Delete"/>

Wireless Security

Parameter	Value
60 ghz airlink SSID	<input type="text" value="[default]"/>
60 ghz airlink encryption passkey	<input type="text" value="[default-passkey]"/>

Wireless tab — Configuration section

The following configuration settings are used to make the device's links unique, in order to form and secure a wireless connection with another device and to avoid co-channel interference.

Wireless role — The P421 can only serve in a DN (distribution node) role.

GPS synchronization — Enables or disables GPS synchronization. The P421 uses GPS for location and TDMA synchronization. When GPS Synchronization is enabled or disabled, the device will reboot once the change is submitted.

Description — Enter a meaningful description to assist field technicians during installation or troubleshooting. For example, "Pole 37, aimed toward KB-C6-xx-xx".

Channel set the channel frequency, 1-4.

Channel	Center (GHz)	Min. (GHz)	Max. (GHz)
1	58.32	57.24	59.40
2	60.48	59.40	61.56
3	62.64	61.56	63.72
4	64.80	63.72	65.88

Golay index set the Golay index, 1-3. Golay index can be useful for avoiding certain types of co-channel interference. See [Design and deployment](#).

Polarity set polarity to odd or even.

DN responder is automatically set if DN link auto-configuration is used. The represents the MAC address for the wireless interface to a remote distribution node. Only one DN responder link is allowed.

The **Submit Changes** button resets the link configuration to the values selected. Link configuration changes are shown in the Wireless Status table as they become complete.

Note: Enable/disable **GPS Synchronization** causes a reboot of the device.

Wireless tab — Wireless section

The wireless status table is the same information shown in the Wireless table on the Status tab. The table in this area shows wireless link status for the unit. Use the horizontal scroll bar to view all values.

Wireless													
Radio	MAC Address	Description	Chan	DN/ CN	Peer- Name	Link State	SNR	RSSI	TX MCS	TX Power Index	TX angles	RX angles	
0	70:88:6b:c7:00:01	Techpubs radio 0	1	DN	KB-C7-00-01	UP 20:34:53	18/15	-56/-59	9/9	6/6	7/0 -3.5/7.5	8.75/0 -3.5/7.5	

- **Link State** lists the state of the link and the length of time that the link has been up or down. Values are:
 - **Up** — The link is functioning normally.
 - **Up but blocked** — The link is formed but is being blocked by [Spanning Tree Protocol](#).
 - **Down** — The link is down. Includes the number of unsuccessful linkup attempts.
- **SNR, RSSI, TX MCS, TX Power Index, TX angles, and RX angles** show values for both ends of the link, in local/remote order.
- **TX angles** and **RX angles** refer to the beam angle when looking from behind the radio towards the linked peer.
 - A positive value refers to the beam angle to the right of boresight.
 - A negative value refers to the beam angle to the left of boresight.

Tip: The hostnames listed under **Peer-Name** are clickable links and will open the radio's WebUI in a new browser tab.

Wireless tab — DN link auto-configuration section

See [DN link auto-configuration](#) for information about the **DN link auto-configuration** section.

Wireless tab — Wireless Security section

All AltoPlex devices have the same default SSID and encryption passkey for their 60 GHz airlink. Generally, this is sufficient because the devices will only form links to radios that are specified in their configuration.

All linked radios must have the same SSID and encryption passkey. If you change the SSID and/or passkey, they must be changed for all linked radios or the links will not form.

Note: When changing the SSID and passkey for radios that are already installed in the field, begin with the most remote devices, moving backwards towards the point of presence. This insures that you will have access to all radios during the process.

To change the SSID and encryption passkey for the 60 GHz airlink:

1. Click the **login** link in the WebUI header to log in as administrator. The default password is **admin**.

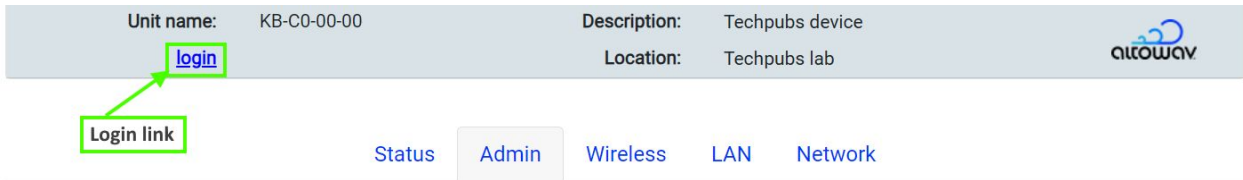

2. For **60 ghz airlink SSID**, type the new SSID.
3. For **60 ghz airlink encryption passkey**, type the new encryption passkey.
4. A confirmation screen will remind you that the SSID and passkey must be the same for all linked devices, and will indicate that the device will reboot in order to complete the change. Click **Yes** to confirm.

LAN tab

The LAN tab provides settings for enabling Ethernet traffic on the LAN port for the P421.

Unit name: KB-C0-00-00	Description: Techpubs device	
Logged in as: admin (logout)	Location: Techpubs lab	

Status
Admin
Wireless
LAN
Network

Ethernet Port Configuration

Interface number:	1
Port enable	<input checked="" type="checkbox"/> Enable

Discard Changes
Submit Changes



MAC Filter Configuration

Parameter	Value
Ethernet port 1 mac limit	Unlimited ▼
Ethernet port 1 destination mac address	<input style="width: 100%;" type="text"/>
Ethernet port 1 unicast conversion	<input type="checkbox"/> Enable

Discard Changes
Submit Changes

LAN tab — Ethernet Port Configuration

Port enable — Check or clear the box to enable/disable the Ethernet port traffic. The PoE input remains active. The port is enabled by default.

Tip: In the WebUI, hover over the port in the graphic to show the current connection status of the port.

LAN tab — MAC Filter Configuration

AltoPlex radios support both source and destination MAC filtering.

- **Source MAC filtering** — Configures the radio to forward network traffic on its Ethernet port only if the traffic is originating from specific MAC addresses.

On AltoPlex radios, source MAC filtering is configured by setting the number of allowed MAC addresses (up to 10 are supported). The radio then automatically populates an allowlist that contains the first devices that connect to the Ethernet port, up to the configured limit. Traffic is not forwarded from any devices not on the allowlist.

- You clear the allowlist by either rebooting the radio or making a change to the configuration, at which point a new allowlist will be automatically created.
- **Destination MAC filtering** — Configures the radio's Ethernet port to only forward unicast network traffic to a specified destination MAC address. Network traffic with a destination MAC address that matches the configured MAC will be forwarded. All other network traffic will be dropped.

You can also configure the radio to convert broadcast and multicast traffic into unicast and forward it to the configured destination MAC address. This may be useful for certain types of broadcast or multicast network traffic, such as DHCP requests.

Configure MAC filtering

In the **MAC Filter Configuration** section of the **LAN** tab:

1. Configure source MAC filtering:
 - A. For **Ethernet port 1 mac limit**, select the number of MAC addresses to be included in the allowlist. Allowed values are **1-10** and **Unlimited**. The default is **Unlimited**, which means that source MAC filtering is disabled.
 - B. An allowlist is automatically generated based on the first MAC addresses that connect to the device after source MAC filtering is enabled, up to the configured limit.
 - You can repopulate the allowlist by rebooting the radio or making a configuration change.
 - See [Show the current MAC filter configuration](#) for information about how to determine the current source filter allowlist.
2. Configure destination MAC filtering:
 - A. For **Ethernet port destination mac address**, type the destination MAC address that unicast network traffic must contain for the traffic to be forwarded.
 - B. For **Ethernet port unicast conversion**, click **Enable** to convert broadcast and multicast network traffic to unicast and forward that traffic to the specified destination MAC address.
3. Click **Submit Changes**.

Show the current MAC filter configuration

You can show the current MAC filter configuration, including the current allowlist that the radio is using for source MAC filtering, by using either the CLI or the REST API.

- **CLI:**

1. Log in via ssh to the P421:

```
$ ssh admin@<hostname>
admin@<hostname>'s password:
```

where *hostname* is the hostname (for example, KB-C7-00-01) or IP address of the radio. See [Connecting to the P421](#) for more information.

2. Use the **mac_filter_status** command:

```
KB-C7-00-01> mac_filter_status
  kb_name: KB-C7-00-01
  ports:
    eth1:
      filter_eth1_destination_mac: 70:88:6B:C7:00:02
      filter_eth1_unicast_conversion: enable
      filter_eth1_source_mac_limit: 4
      source_mac_allowlist:
        a0:b1:c2:d3:e4:f5
        0a:1b:2c:3d:4e:5f
        ff:ee:dd:cc:bb:aa
        00:11:22:33:44:55
```

- **REST API:**

Use the **device/mac_filter_status** API. For example:

1. In your browser, type the following URL in the address bar:

```
https://<hostname>/rest/v002/device/mac_filter_status?output=text
```

where *hostname* is the hostname (for example, KB-C7-00-01) or IP address of the radio.

2. The following output is displayed in the browser window:

```
kb_name: KB-C7-00-01
ports:
  eth1:
    filter_eth1_destination_mac: 70:88:6B:C7:00:02
    filter_eth1_unicast_conversion: enable
    filter_eth1_source_mac_limit: 4
    source_mac_allowlist:
      a0:b1:c2:d3:e4:f5
      0a:1b:2c:3d:4e:5f
      ff:ee:dd:cc:bb:aa
      00:11:22:33:44:55
```

Network tab

The top half of the **Network** tab contains Network Reachability Configuration settings. They include settings for Management Network Interfaces, VLAN Configuration and Port Isolation.

Unit name: KB-C0-01-14

Logged in as: admin ([logout](#))

Description: system description not set

Location: system location not set



Status Admin Wireless LAN Network

Network Reachability Configuration

– Management Network Interface Configuration –

Parameter	Value
IP assignment method	<input type="radio"/> Static <input checked="" type="radio"/> Dynamic
IP address (static)	<input type="text" value="192.168.0.1"/>
Network mask (static)	<input type="text" value="255.255.0.0"/>
Network gateway (static)	<input type="text" value="192.168.0.1"/>

– Virtual LAN Configuration –

Parameter	Value
VLAN 802.1q mode	<input checked="" type="radio"/> Disable <input type="radio"/> Enable
Management 802.1q VLAN ID	<input type="text" value="1"/>
Ethernet port 1 802.1q accepted frame types	<input checked="" type="radio"/> All <input type="radio"/> Tagged
Ethernet port 1 802.1q PVID	<input type="text" value="1"/>
Ethernet port 1 802.1q membership	<input type="text" value="1"/> <input type="button" value="X"/> <input type="text"/> <input type="button" value="+"/>

– Port Isolation –

Parameter	Value
Ethernet port 1 isolation	<input type="checkbox"/> Enable
Wireless port isolation	<input type="checkbox"/> Enable

Network tab — Network Reachability Configuration section

Management Network Interface Configuration

By default, AltoPlex radios use dynamic IP address assignment and, beginning with release 3.6.0, have a factory default fallback static IP address of 192.168.0.1. Additionally:

- Radios can be configured to use a static IP address, rather than dynamic IP address assignment. This will override the factory default fallback IP.

- Radios upgraded to release 3.6.0 that have not been factory reset will have a factory default fallback IP address of 192.168.0.51, unless they have a configured static IP address that overrides the default address.
- For radios with a firmware release prior to 3.6.0, the factory default fallback IP address will be the address that was included on the sticker when the device was originally shipped.

Click **Static** to configure the radio to use a static IP address rather than dynamic IP address assignment. Configure the **IP address**, **Network mask** and **Network gateway**.

Virtual LAN Configuration

VLAN 802.1q mode — Select **Enable** to enable VLAN support on this radio.

Management 802.1q VLAN ID — The identification number of the VLAN used for management purposes.

Ethernet port x 802.1q accepted frame types — For VLANs that the port is a member of, accept **All** incoming Ethernet packets, or only packets that are **Tagged**.

Ethernet port x 802.1q PVID — The Port VLAN ID (PVID). This determines what VLAN ID will be assigned to untagged frames.

Ethernet port x 802.1q membership — The VLANs that this Ethernet Port is a member of. Allowed values are single integers, a range of integers, or both. Values should be comma-separated without spaces. For example, 1,6,10-15. Maximum value is 4094.

Ethernet port x isolation — Click **Enabled** to restrict traffic between nodes in the VLAN over the Ethernet interface.

Wireless port isolation — Click **Enabled** to restrict traffic between nodes in the VLAN over the Wireless interface.

Network tab — Spanning Tree Protocol Configuration

Spanning Tree Protocol Configuration

Parameter	Value
Spanning tree protocol (stp) enable	<input type="checkbox"/> Enable
STP bridge priority	<input type="text" value="8"/>
STP radio 0 port path cost	<input type="text" value="20000"/>
STP Ethernet port 1 bpdu filter	<input type="checkbox"/> Enable

Spanning tree protocol — Enable/disable spanning tree protocol (STP) by checking/clearing the box. If enabled, optionally set the bridge priority and port path cost for the wireless interface.

STP bridge priority is used to determine which device will serve as the root of the spanning tree. The device with the lowest priority will serve as the root. The priority configured here is a multiplier; to determine the actual STP priority, multiply by 4096.

The **STP port path cost** is used to determine the preferred path to the root. The path with the lowest cumulative cost is used.

The **STP Ethernet port 1 bpd filter** prevents BPDU packets from being forwarded, which allows for separate networks to be isolated from participating in the same STP environment. When enabled, the filter is applied whether or not Spanning Tree Protocol is enabled.

Network tab — SNMP Configuration

Simple Network Management Protocol (SNMP) is used to monitor devices on a network for performance and error information. The settings in this section enable/disable SNMP and configure notification and community access settings.

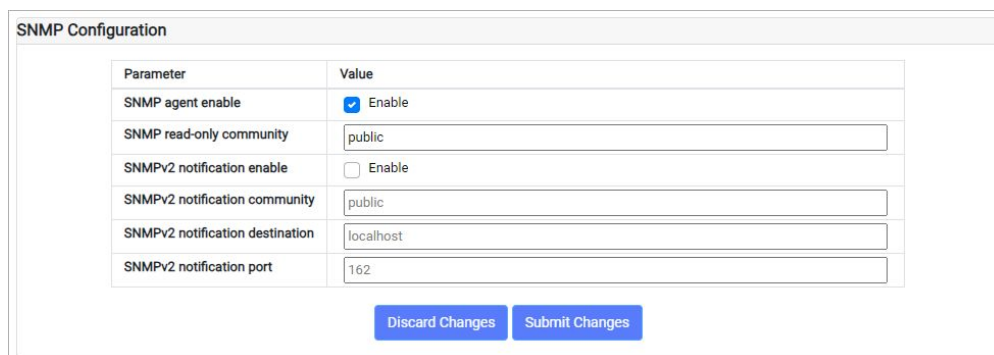

Parameter	Value
SNMP agent enable	<input checked="" type="checkbox"/> Enable
SNMP read-only community	public
SNMPv2 notification enable	<input type="checkbox"/> Enable
SNMPv2 notification community	public
SNMPv2 notification destination	localhost
SNMPv2 notification port	162

The Altowav enterprise MIB can be downloaded at <https://www.altowav.com/technology/assets/pdf/ALTOWAV-MIB.mib>.

Network tab — Network Services Configuration

DNS IP list — A list of DNS server IP addresses using commas to separate the addresses.

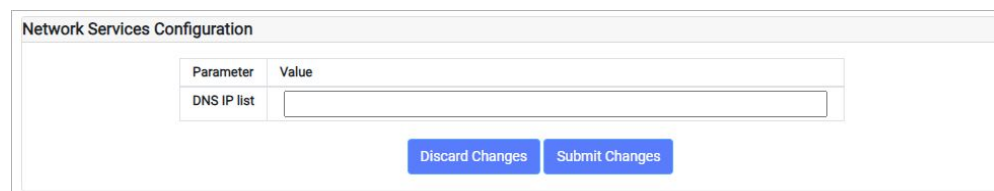

Parameter	Value
DNS IP list	

Network tab — DHCP Relay Configuration (Option 82)

Enable the DHCP relay agent to:

- Prevent unauthorized DHCP servers from serving IP addresses to devices on your network.
- Insert a circuit ID into a DHCP message that identifies the source of the message. The **DHCP relay agent circuit ID type** can be either **HWaddr** (the MAC address of the P421's Ethernet port, in ASCII format), or the **Hostif** (the hostname:Ethernet_port of the P421 in ASCII format).

You can also select whether the Ethernet port is:

- **Trusted** — All DHCP packets coming from devices attached to the Ethernet port will be forwarded.
- **Untrusted:**
 - All DHCP server packets from attached devices will be blocked.
 - All DHCP client packets from attached devices that have option 82 information in their header will be blocked.
 - All DHCP client packets from attached devices that do not have option 82 information in their header will be forwarded, with the circuit ID appended.

Note: All wireless links are automatically considered trusted.

DHCP Relay Configuration (Option 82)

Parameter	Value
DHCP relay agent enable	<input type="checkbox"/> Enable
DHCP relay agent circuit ID type	<input checked="" type="radio"/> HWaddr <input type="radio"/> Hostif
Ethernet port 1 host access	<input checked="" type="radio"/> Trusted <input type="radio"/> Untrusted

Maintenance and security

Wi-Fi connection to a P421

Connect to a P421 via Wi-Fi to access the WebUI for diagnostic purposes and configuration tasks, if required.

Note: The Wi-Fi connection to the P421 provides a connection to the device for management and diagnostic purposes. It does not provide a connection to the an external network, or to the internet.

Some scenarios where this may be useful:

- If the device's WebUI is unreachable via standard access methods. This could happen if Network settings were inadvertently set to unworkable values, or if a direct connection is not feasible due to where the unit is mounted.
- When a device is reset to factory defaults, a Wi-Fi connection may be useful to reconfigure settings after the reset.
- After the initial install of a device, if links do not come up as expected per your design, a Wi-Fi connection could be used to verify and update configurations. This may be especially helpful in cases where the unit is rotated, resulting in sector orientation that is different from the design plan, or in cases where bench configuration was done improperly.

Tip: To avoid this issue, make sure links come up as part of the installation process.

- In rare cases, the distribution node could become unreachable after configuration and operation in a network. If the unit cannot be reached via wireless or Ethernet link, the unit may be reachable via Wi-Fi.

Wi-Fi settings

Settings for Wi-Fi access are in the Configuration section of the **Admin** tab of the WebUI.

Parameter	Value
Location	Techpubs lab
Description	Techpubs device
Link state LED	<input checked="" type="checkbox"/> Enable
AltoCommand server	cloud.altocommand.altowav.com
Diagnostic wifi access point	<input checked="" type="checkbox"/> Enable
WiFi ap SSID	KB-C7-00-01
WiFi ap password	AltoWav@123
WiFi ap IP address(static)	192.168.5.1
Hide SSID	<input type="checkbox"/> Enable

Default for **Diagnostic Wi-Fi access point** is enabled.

Default **Wi-Fi ap SSID** is the hostname of the device. (Listed as HN: KB-XX-XX-XX on the device label.)

Default **Wi-Fi ap password** is **AltoWav@123**.

Default **Wi-Fi ap IP address** is 192.168.5.1. This is the static IP for the device's Wi-Fi access point.

If **Hide SSID** is enabled, the Wi-Fi SSID will not be broadcast.

Prerequisites for connecting to the P421 via Wi-Fi:

- You must be in close range to the P421 in order to connect to it via Wi-Fi — generally within 10 - 20 ft.
- A P421 allows only one incoming connection to Wi-Fi at a time. If multiple technicians are on site, only one may be connected.

To access a device via Wi-Fi:

1. Scan for possible Wi-Fi connections.
2. Find the device's hostname and select **Connect**.
3. Enter the **Wi-Fi ap password**.
4. Browse to the device's **Wi-Fi ap IP address** to open the WebUI.

The WebUI opens to the **Status** tab.

Change the device password

For all AltoPlex devices, passwords can be changed using the WebUI. The process is the same for all devices.

Note: Take care when changing passwords, so that the device's WebUI is not rendered unreachable.

To change the device password:

1. Access the WebUI of the P421. In your browser's address bar, type:

https://hostname

where *hostname* is the hostname (KB-XX-XX-XX) or IP address of the radio. See [Connecting to the P421](#) for more information.

2. Click the **login** link in the WebUI header to log in as administrator. The default password is **admin**.

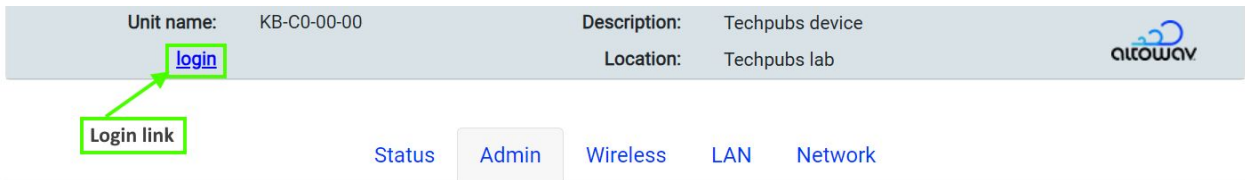

3. Click the **Admin** tab.
4. Click the **Change Password** button in the **Device control** section.

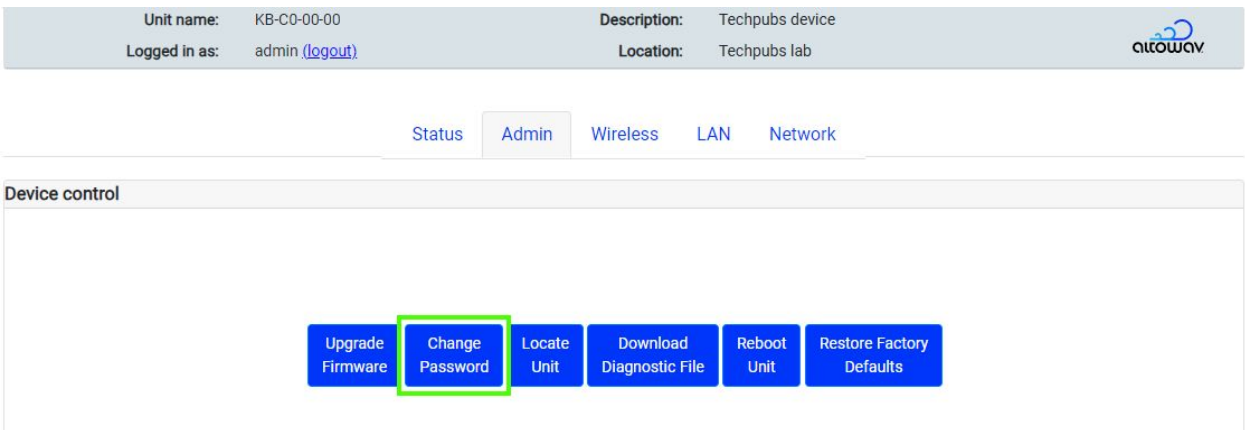

The **Change user password** dialog opens.

5. Enter and re-enter the new password and click **Change Password**.

Enable Passwordless SSH

By default, the P421 requires a password to log onto the device when using SSH. You can use the **ssh_keys** CLI command to configure passwordless SSH login to the P421.

Note: This procedure describes how to upload an SSH key to the P421. You need to generate the SSH key on your local machine using a tool such as the Linux **ssh-keygen** command.

1. Log in via ssh to the P421:

```
$ ssh admin@<hostname>
admin@<hostname>'s password:
```

where *hostname* is the hostname (for example, KB-C7-00-01) or IP address of the radio. See [Connecting to the P421](#) for more information.

2. Enter **control** mode:

```
KB-C7-00-01> control
KB-C7-00-01 (control)>
```

3. Use the **ssh_keys** command:

- Use **ssh_keys add file *user@host:/path*** to add a key that is stored on a different host, where:
 - *user* is the username to log into the host.
 - *host* is the name of the host machine.
 - *path* is the path and filename of the key file.
- Use **ssh_keys add text *key*** to add a key by copying the contents of the key file and pasting the contents as an argument of the **ssh_keys add** command.
- Use **ssh_keys show** to return a list of installed keys.
- Use **ssh_keys delete *number*** to uninstall the key specified by *number*. The number of the key is determined with the **ssh_keys show** command.
- Use **ssh_keys delete all** to uninstall all keys.

Note: All authorized keys are deleted when a factory reset is performed.

Upgrading firmware

Upgrade roadmap

1. Download and unzip the firmware zip file from [Altoplex Firmware Downloads](https://support.altoway.com) at support.altoway.com.
2. Upgrade the devices one at a time.
3. Always start with the P421 furthest from the root node.

The firmware binary filename

The following files are included in the firmware zip file:

- A digest file, not used as part of this upgrade process.
- The firmware binary.

The firmware binary filename consists of three parts:

<filetype>-<device_family_name>-<version_number>

where:

- *filetype* is **kb_sw-prod**
- *device_family_name* is one of:
 - **NOMAD** — Firmware used for D621 and P621 devices.
 - **DEVO** — Firmware used for D423, C410, C420, and P421 devices.
- *version_number* is the version number of the firmware.

For example:

kb_sw-prod-DEVO-4.2.0

Upgrade from the WebUI

1. Download and unzip the firmware zip file from [Altoplex Firmware Downloads](http://support.altowav.com) at support.altowav.com.

The following files are included in the firmware zip file:

- A digest file, not used as part of this upgrade process.
- The firmware binary. See The upgrade software filename for information about the filename used for the firmware binary.

2. Access the WebUI of the P421. In your browser's address bar, type:

https://hostname

where *hostname* is the hostname (KB-XX-XX-XX) or IP address of the radio. See [Connecting to the P421](#) for more information.

3. Click the **login** link in the WebUI header to log in as administrator. The default password is **admin**.

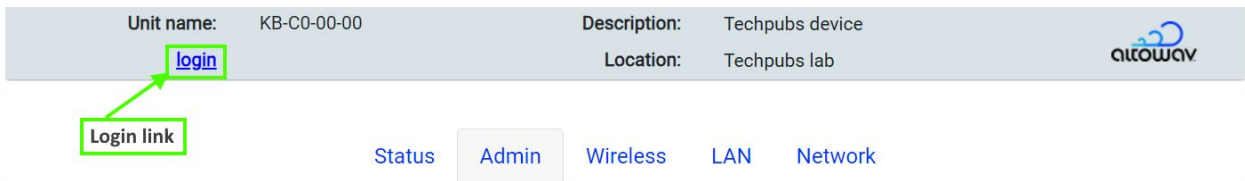

4. Click the **Admin** tab.
5. Click the **Upgrade Firmware** button.

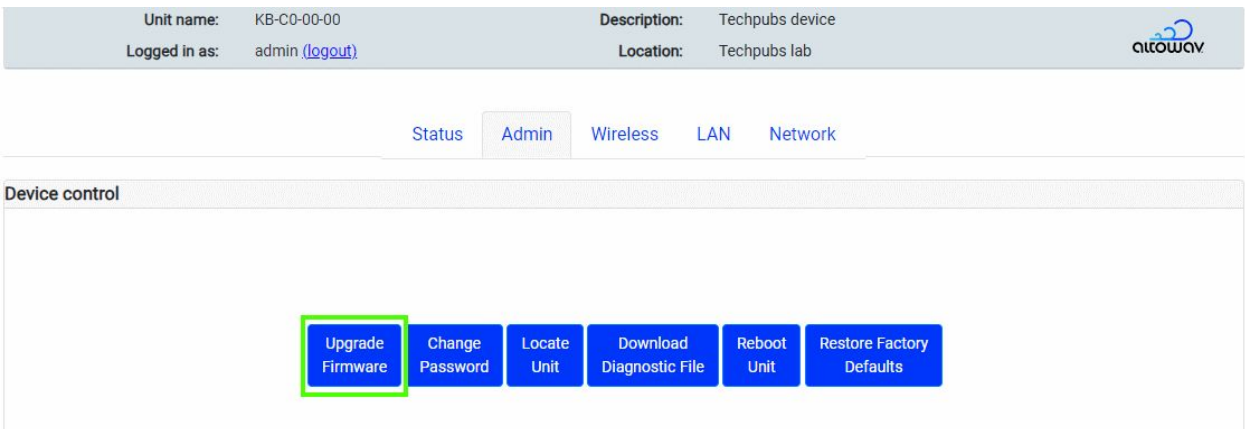

The **Firmware upgrade** dialog opens.

6. Click **Choose File**.
7. Browse to the directory where the upgrade binary file was downloaded and select the file.
8. Click **Start Upgrade**.

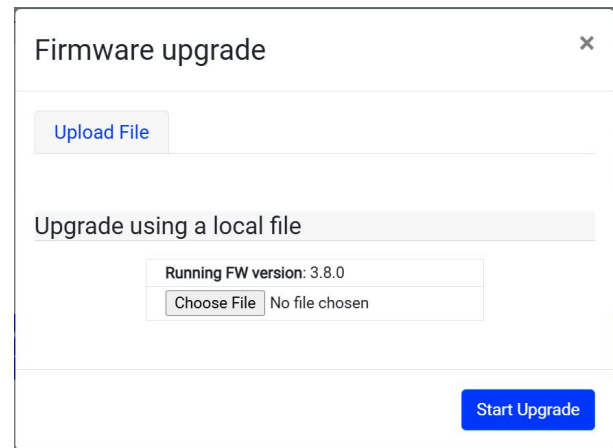

Upgrade from the CLI

Upgrade from the CLI by using Secure File Copy (scp)

Use Secure File Copy (scp) to upload a file from a remote host to the P421 and install the file:

1. Download and unzip the firmware zip file from [Altoplex Firmware Downloads](http://support.altoway.com) at support.altoway.com.

The following files are included in the firmware zip file:

- A digest file, not used as part of this upgrade process.
- The firmware binary. See The upgrade software filename for information about the filename used for the firmware binary.

2. Log in via ssh to the P421:

```
$ ssh admin@<hostname>
admin@<hostname>'s password:
```

where *hostname* is the hostname (for example, KB-C7-00-01) or IP address of the radio. See [Connecting to the P421](#) for more information.

3. Enter **control** mode:

```
KB-C7-00-01> control
KB-C7-00-01(control)>
```

4. Upload and install the software:

```
KB-C7-00-01(control)> software upgrade scp://user@server/
firmware_filename
```

where:

- *user* is the name of the user on the remote host.
- *server* is the hostname or IP address of the remote host.
- *firmware_filename* is the path and filename of the upgrade software.

5. When prompted, type the password to log into the remote host.

The upgrade software will be uploaded and installed on the P421. You can monitor the status of the upgrade by using the **software status** command:

```
KB-C7-00-01(control)> software status
current-software-version: 3.9.1
status: upgrading
running-sw-version: 3.9.1
new-sw-version: 4.2.0
upgrade-running: yes
```

After the software upgrade completes, the device will reboot.

Upgrade from the CLI by using a TFTP server

1. Download and unzip the firmware zip file from [Altoplex Firmware Downloads](http://support.altowav.com) at support.altowav.com.

The following files are included in the firmware zip file:

- A digest file, not used as part of this upgrade process.
 - The firmware binary. See The upgrade software filename for information about the filename used for the firmware binary.
2. Upload the binary file to the TFTP directory on your server. The TFTP server must be accessible from each device being upgraded.
 3. Log in via ssh to the P421:

```
$ ssh admin@<hostname>
admin@<hostname>'s password:
```

where *hostname* is the hostname (for example, KB-C7-00-01) or IP address of the radio. See [Connecting to the P421](#) for more information.

4. Enter **control** mode:

```
KB-C7-00-01> control
KB-C7-00-01(control)>
```

5. Upload and install the software:

```
KB-C7-00-01(control)> software upgrade tftp://server/firmware_filename
where:
```

- *server* is the hostname or IP address of the TFTP server.
- *firmware_filename* is the path and filename of the upgrade software.

The upgrade software will be uploaded and installed on the P421. You can monitor the status of the upgrade by using the **software status** command:

```
KB-C7-00-01(control)> software status
current-software-version: 3.9.1
status: upgrading
running-sw-version: 3.9.1
new-sw-version: 4.2.0
upgrade-running: yes
```

After the software upgrade completes, the device will reboot.

Upgrade from the REST API

1. Download and unzip the firmware zip file from [Altoplex Firmware Downloads](https://support.altowav.com) at support.altowav.com.

The following files are included in the firmware zip file:

- A digest file, not used as part of this upgrade process.
 - The firmware binary. See The upgrade software filename for information about the filename used for the firmware binary.
2. Upload the firmware image file to a server that can be access by all devices.
 3. Use the `configuration/software_upgrade` API to install the firmware file. For example:

```
curl -k -u admin:<password> \
https://<hostname>/rest/v002/configuration/software_upgrade \
-X POST \
-H "Content-Type:application/octet-stream" \
-H "X-File-Name:<filename>" \
--data-binary@<path>/<filename>
```

Where:

- *password* is the password to log into the device. The default password is **admin**.
- *path* is the path to the firmware file. If the command is executed from the same local directory as the firmware file, path is not necessary.
- *filename* is the name of the firmware upgrade file, for example, kb_sw-prod-DEVO-4.2.0.
- *hostname* is the hostname or IP address of the radio being upgraded.

The following example curl command uses the `-i` option to show the response headers, and demonstrates that the file transfer was successful and that the upgrade has begun:

```
$ curl -i -k -X POST -u admin:admin \
-H "Content-Type:application/octet-stream" \
-H "X-File-Name:kb_sw-prod-DEVO-4.2.0.plain" \
--data-binary @kb_sw-prod-DEVO-4.2.0.plain \
https://10.0.0.01/rest/v002/configuration/software_upgrade
% Total % Received % Xferd Average Speed Time Time Time Current
Dload Upload Total Spent Left Speed
100 34.1M 100 88 100 34.1M 15 6358k 0:00:05 0:00:05 ---:---:-- 6301kHTTP/
1.1 100 Continue

HTTP/1.1 200 OK
Content-Type: application/json
Cache-Control: public, must-revalidate, proxy-revalidate
Content-Length: 88
Date: Sat, 01 Jan 2025 00:23:39 GMT
Server: lighttpd/1.4.73
{
```

```
"status": "starting",
"running-sw-version": "3.9.1",
"upgrade-running": "yes"
}
```

The upgrade may take up to several minutes to complete.

Verify that the firmware update was successful

Verify firmware update from the WebUI

1. Open the WebUI.
2. The firmware version is displayed on the **Status** page in the **Device Information** section:

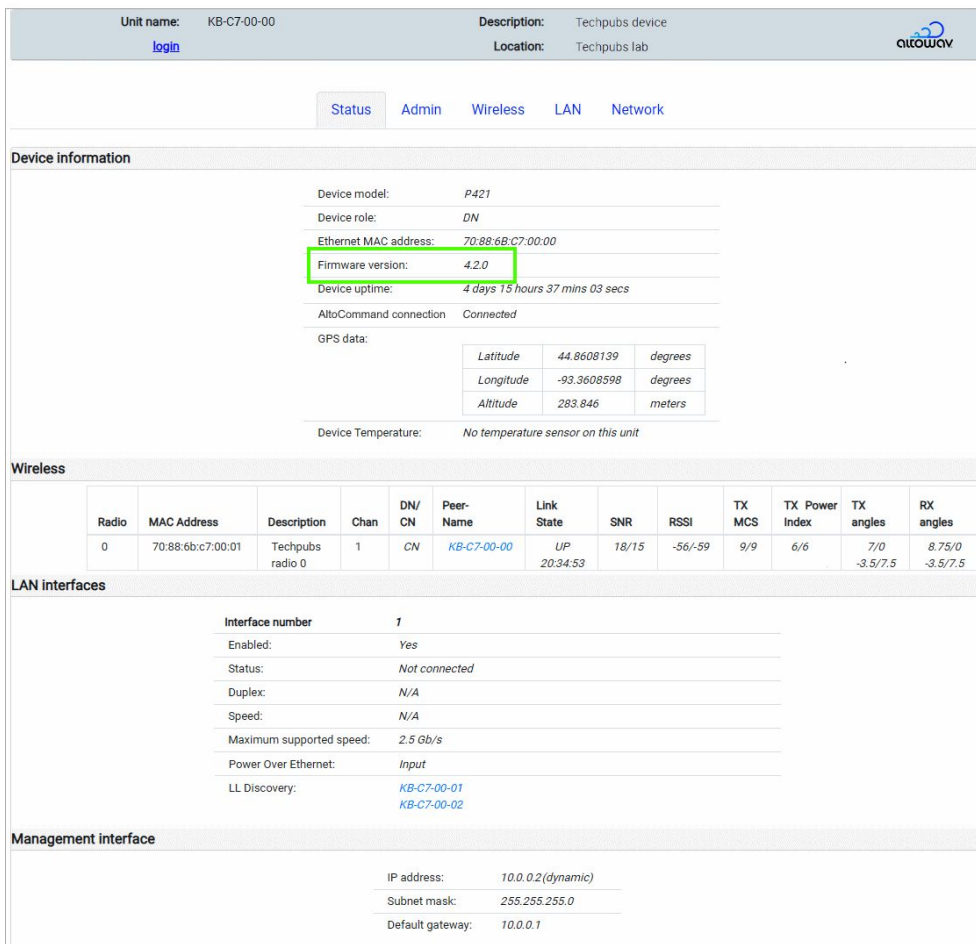

The screenshot shows the WebUI interface for a P421 device. The top navigation bar includes 'Status', 'Admin', 'Wireless', 'LAN', and 'Network'. The 'Status' page displays the following information:

- Unit name:** KB-C7-00-00
- Description:** Techpubs device
- Location:** Techpubs lab

Device information section:

- Device model: P421
- Device role: DN
- Ethernet MAC address: 70:88:6B:C7:00:00
- Firmware version: 4.2.0** (highlighted with a green box)
- Device uptime: 4 days 15 hours 37 mins 03 secs
- AltoCommand connection: Connected
- GPS data:

Latitude	44.8608139	degrees
Longitude	-93.3608598	degrees
Altitude	283.846	meters
- Device Temperature: No temperature sensor on this unit

Wireless section:

Radio	MAC Address	Description	Chan	DN/ CN	Peer- Name	Link State	SNR	RSSI	TX MCS	TX Power Index	TX angles	RX angles
0	70:88:6b:c7:00:01	Techpubs radio 0	1	CN	KB-C7-00-00	UP 20:34:53	18/15	-56/-59	9/9	6/6	7/0 -3.5/7.5	8.75/0 -3.5/7.5

LAN interfaces section:

- Interface number: 1
- Enabled: Yes
- Status: Not connected
- Duplex: N/A
- Speed: N/A
- Maximum supported speed: 2.5 Gb/s
- Power Over Ethernet: Input
- LL Discovery: KB-C7-00-01, KB-C7-00-02

Management interface section:

- IP address: 10.0.0.2 (dynamic)
- Subnet mask: 255.255.255.0
- Default gateway: 10.0.0.1

Verify firmware update from the command line

1. Log in via ssh to the P421:

```
$ ssh admin@<hostname>
```

admin@<hostname>'s password:

where *hostname* is the hostname (for example, KB-C7-00-01) or IP address of the radio. See [Connecting to the P421](#) for more information.

2. Enter **control** mode:

```
KB-C7-00-01> control
KB-C7-00-01(control)>
```

3. Check the status of the device by using the **software status** command:

```
KB-C7-00-01(control)> software status
current-software-version: 4.2.0
status: idle
upgrade-running: no
KB-C7-00-01(control)>
```

Verify that the current-software-version matches the expected value of the upgrade.

Verify firmware update from the REST API

Use the `device/node_identity` API to return the firmware version:

```
$ curl -k -u admin:admin https://KB-C7-00-01/rest/v002/device/node_identity
% Total    % Received % Xferd  Average Speed   Time    Time     Time
Current                        Dload  Upload  Total   Spent    Left
Speed
100 605  100  605    0    0  8188      0 --:--:-- --:--:-- --:--:--
8402{
  "Ethernet MAC" : "70:88:6B:C7:00:01",
  "HW name" : "devo",
  "HW rev" : 2,
  "HW type code" : 82,
  "Node role" : "DN",
  "Number Ethernet Interfaces" : 1,
  "Number RF Interfaces" : 1,
  "Part number" : "1900-8411-1012-devo-2-LBKA0ZZ1SV1",
  "Serial number" : "000000000000000000000001KB-C7-00-01:2",
  "authorized_org" : "",
  "bootloader version" :
"KBBLVERSION:1.3:prod:robot:2025-12-04_11-57-10:devo:1b565eb",
  "description" : "system description not set",
  "gps available" : 1,
  "location" : "system location not set",
  "name" : "KB-C7-00-01",
  "node type" : "PTP",
  "software" : "4.2.0"
}
```

Reboot a device

Note: A power-cycle or reboot clears the diagnostic log information stored in the device. So during troubleshooting, you should capture the diagnostic log in a file, before the power-cycle or reboot. If you require troubleshooting assistance, information in the diagnostic log may be useful.

1. Access the WebUI of the P421. In your browser's address bar, type:

https://hostname

where *hostname* is the hostname (KB-XX-XX-XX) or IP address of the radio. See [Connecting to the P421](#) for more information.

2. Click the **login** link in the WebUI header to log in as administrator. The default password is **admin**.

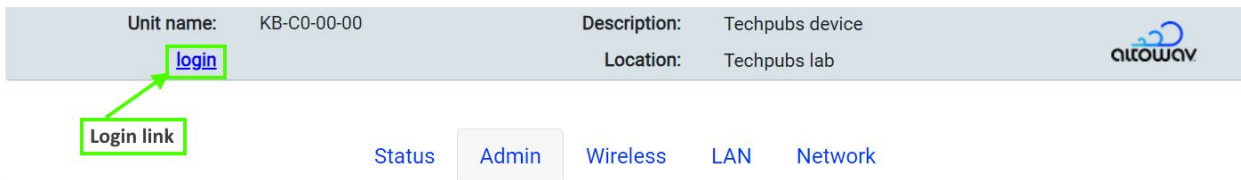

3. Click on the **Admin** tab, entering the password to log in when prompted.
4. Click on the **Reboot Unit** button in the **Device control** section and wait until the reboot is complete.

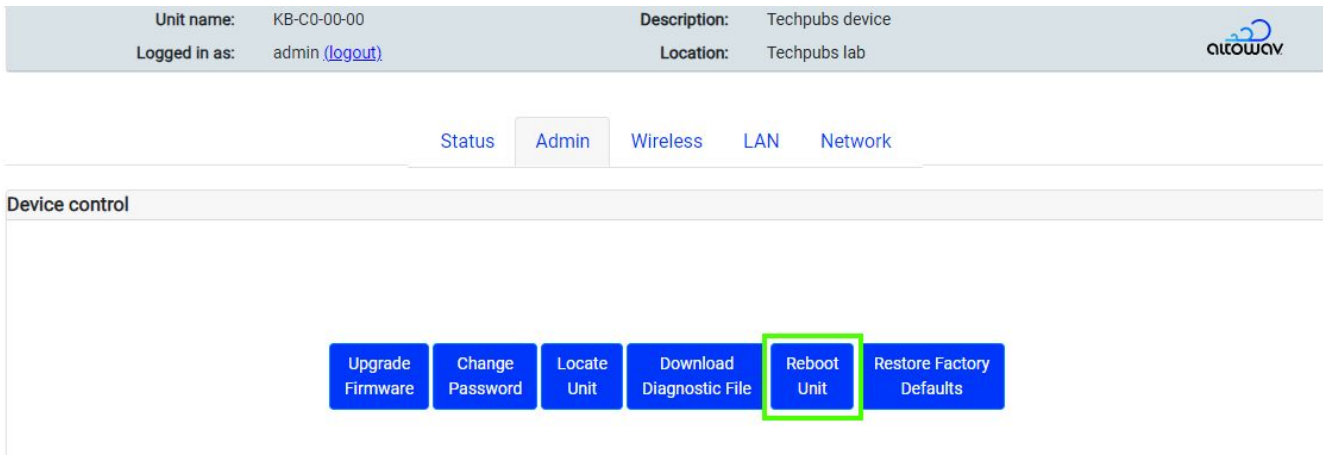

Tip: View the **Wireless** table on the **Status** tab to verify that links for this device have come up again.

If you are unable to reach the device's WebUI but are near the unit and can physically disconnect it from power, a power cycle will perform a hard reboot of the device.

Factory reset

Note: If you factory reset one of the radios in a bridged pair, the bridge between the radios will no longer work. Follow the instructions for [Configure a replacement radio](#) to reconfigure the devices to form a bridged connection.

Restore factory defaults by using the WebUI

Use the **Restore Factory Defaults** button in the device's WebUI to reset the device.

1. Access the WebUI of the P421. In your browser's address bar, type:

https://hostname

where *hostname* is the hostname (KB-XX-XX-XX) or IP address of the radio. See [Connecting to the P421](#) for more information.

2. Click the **login** link in the WebUI header to log in as administrator. The default password is **admin**.

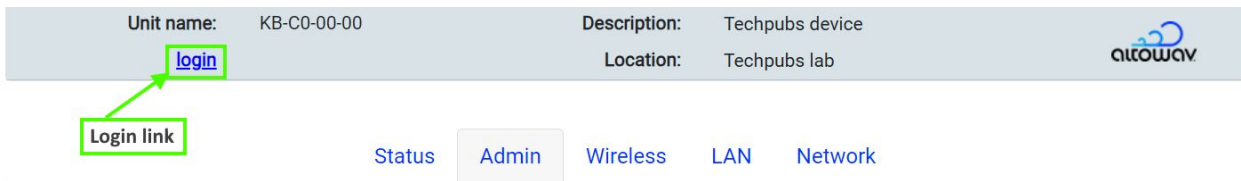

3. Click on the **Admin** tab, entering the password to log in when prompted.
4. Click on the **Restore Factory Defaults** button in the **Device control** section.

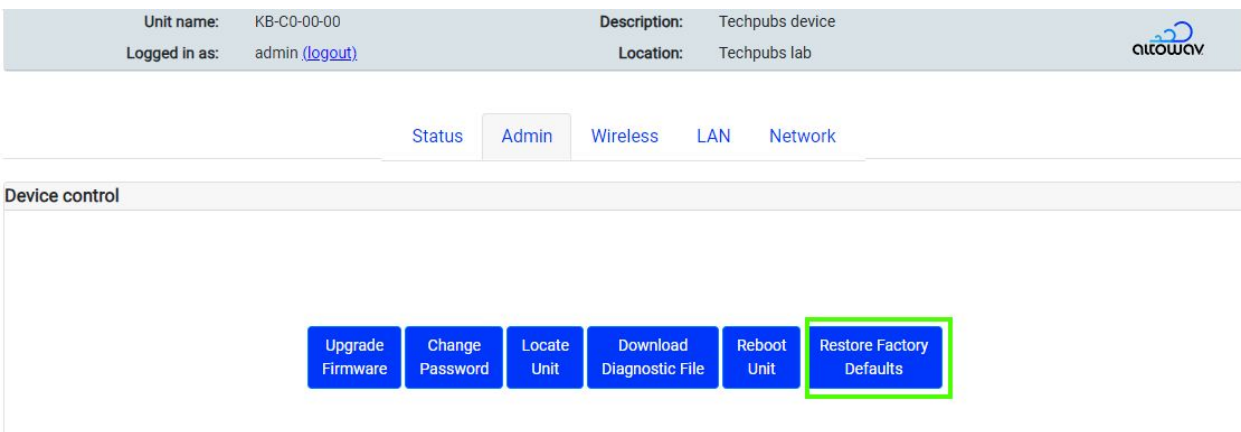

5. A confirmation dialog opens. Enter the text **confirm factory reset** and click **OK**.

After the reset, the device reboots with factory default settings. The login credentials for the device return to **admin**. Reconfigure the device as necessary to reestablish radio links, set location and description, and configure the network settings.

Restore factory defaults by using the factory reset button

If the WebUI is inaccessible due to a lost password or in cases where network settings are inadvertently set to unworkable values, use the following hard factory reset steps. After the reset, normal operation resumes with factory default settings.

1. To access to the reset button, the Ethernet port on the device must be uncovered. If the cable gland is in place, unscrew or remove the gland.

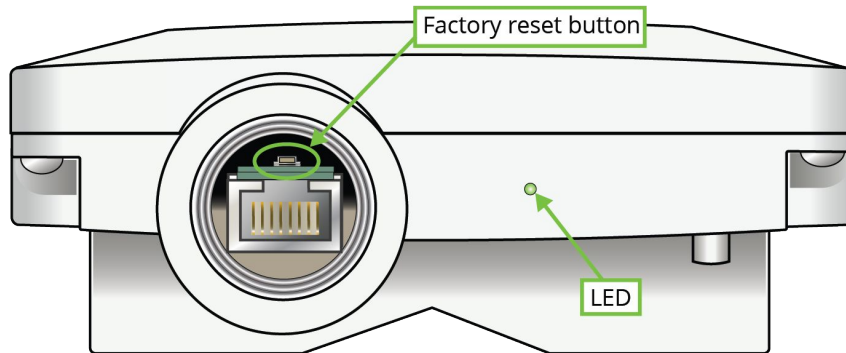

2. [Reboot](#) or power cycle the device.
 - While the device is powering up, The LED will be solid red.
 - After powering up, the the LED will begin flashing red/green, pausing, then flashing red/green again.

This indicates that the device is ready for the factory reset button to be pressed. The device will stay in this mode for approximately ten seconds, or until the factory reset button is pressed.
3. Insert a wood or plastic pin into the factory reset button above the RJ45 port. Push down and hold.
4. Continue to hold the reset button down until the LED flashes a red and green sequence, then release the button.
5. The LED is solid red while the device boots.
6. When the LED flashes green, the reset is complete.

After the reset, the device reboots with factory default settings. The login credentials for the device return to **admin**. Reconfigure the device as necessary to reestablish radio links, set location and description, and configure the network settings.

Troubleshooting

This chapter contains the following topics:





- [LED Indicators](#)
- [Lost Password](#)
- [Download a Diagnostic File](#)
- [MAC addresses used by the P421](#)

LED Indicators

The P421 is equipped with a single LED, showing both red and green lights to indicate power, connection and activity.

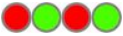
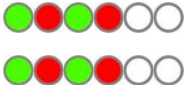

The light sequences indicate the state of the unit. The following table shows the meaning of the light sequences.

LED behavior		Indicates
	Solid red	Device is powering up.
	Slow flashing green	Device is waiting for GPS to synchronize. If the device is the wireless responder, the LED will stop slow flashing once a connection to the wireless initiator has been established, whether or not GPS has synchronized on the responder.
	Flashing green	Device is waiting to form a wired connection and at least one wireless connection.
	Solid green	Device has a wired connection and at least one wireless connection.
	Flashing red/green	Device is in locate mode.
	Flashing red/green, pausing, then flashing red/green again.	Device is booting and ready for the factory reset button to be pressed. The device will stay in this mode for approximately ten seconds, or until the factory reset button is pressed. See Factory Reset for information about performing a factory reset.

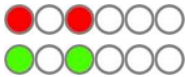
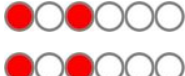
	<p>Flashing red, pausing, then flashing green, pausing, then repeating.</p>	<p>The factory reset button has been pressed and the device is performing a factory reset.</p>
	<p>Flashing red, pausing, then repeating.</p>	<p>Error condition.</p>

Lost Password

If a P421 device password is lost, the device may have to be [reset to factory defaults](#).

After the reset, operation resumes with factory default settings, including the default password: **admin**.

Download a Diagnostic File

Altowav is committed to providing high quality technical support. If you encounter an unusual issue that you cannot easily solve through standard troubleshooting, please contact us at support@altowav.com with the following information:

- Your contact information.
- The type and model of hardware with the issue.
- Product serial number.
- A description of the issue.

We also recommend that you provide a diagnostic log of device interactions and conditions.

Note: A diagnostic log file captures historical information about a device's operation. It is important to download the diagnostic file before rebooting or power-cycling a device as part of troubleshooting. Rebooting or power-cycling will clear the log file history.

Follow these steps to download a diagnostic file for connected devices from the WebUI:

1. Access the WebUI of the P421. In your browser's address bar, type:

https://hostname

where *hostname* is the hostname (KB-XX-XX-XX) or IP address of the radio. See [Connecting to the P421](#) for more information.

2. Click the **login** link in the WebUI header to log in as administrator. The default password is **admin**.

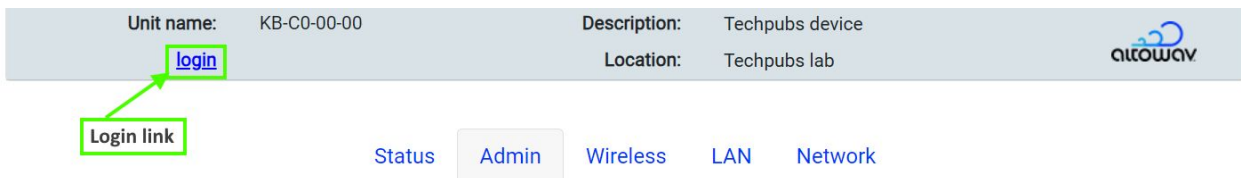

3. Click on the **Admin** tab.

- Click on the **Download Diagnostic File** button in the **Device control** section.

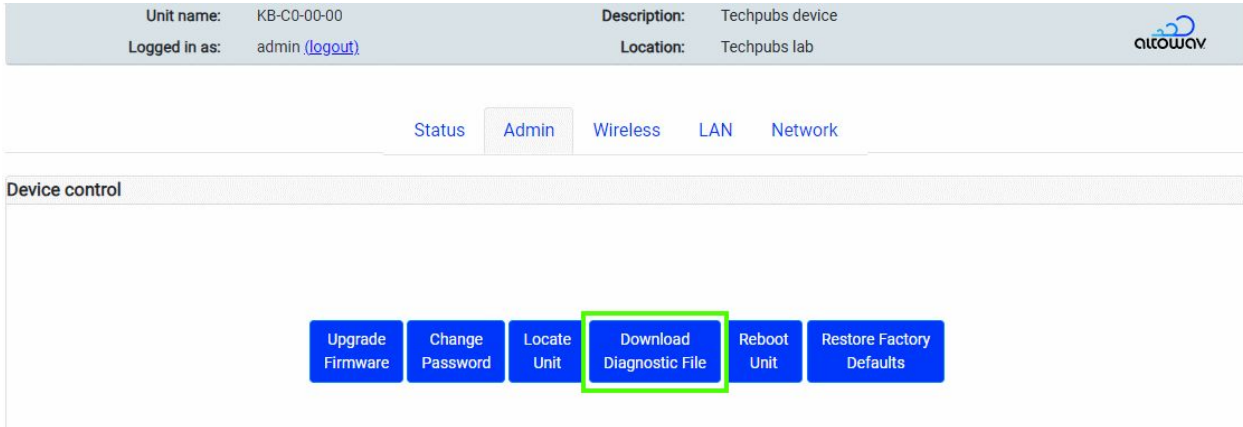

- The file is sent to your system's default download location. The file name includes the host name (KB MAC) of the device and the date. For example, KB-C7-00-01_diag_2025-12-04-20-32-26.txt
- Zip the file and attach it to an email to support@altowav.com or a ticket at support.altowav.com.

Create a diagnostic file from the REST API

- Use the `admin/diagdump` API to create a diagnostic file from the REST API. For example, use the `curl` command to save the diagnostic information to a file named `diag_dump`, created in the current directory:

```
curl -k -o diag_file.txt -u admin:<password> https://<hostname>/rest/v002/admin/diagdump
```

where:

 - `password` is the password to log into the device. The default password is **admin**.
 - `hostname` is the hostname or IP address of the device.
- Zip the file and attach it to an email to support@altowav.com or the ticket at support.altowav.com.

MAC addresses used by the P421

AltoPlex devices have several interfaces that are each assigned unique MAC addresses. These MAC addresses may appear in packet capture software, DHCP server logs, and the device's diagnostic file.

Interface	Description	Example MAC address
60 GHz wireless radio (wlan0)	The MAC address on the device label. The wlan0 interface is also known as Radio 0.	70:88:6B:C7:00:00
Bridge (br0)	Administratively assigned MAC address for the bridge interface. The br0 interface uses the same MAC address as wlan0, except the first octet is 72 rather than 70.	72:88:6B:C7:00:00
eth1	Ethernet port 1 The eth1 interface uses the same MAC address as wlan0, except incremented by one.	70:88:6B:C7:00:01

Note: The device's diagnostic file also contains interfaces that are named kb0* and terra*. These interfaces and their corresponding MAC addresses are for internal use and can be ignored.

Glossary

802.11ay — An enhanced standard for WLANs operating in the 60 GHz spectrum.

Backhaul — Networking infrastructure that connects a local subnetwork to the primary network.
Also known as network backhaul.

Channel — In Wi-Fi networking, a channel is a specific frequency range within a broader range.
The radios in AltoPlex devices can be configured to operate on one of four channels within the 60 GHz spectrum.

Device hostname — In AltoPlex devices, the device hostname uses the last three octets of the device's MAC address, with **KB** appended to the beginning. For example, KB-C7-00-01.

Distribution node — Distribution nodes serve as connected [nodes](#) in a distribution network.
Distributions nodes can provide network access via a wired connection to the backhaul network, wired connections through a switch to other distribution nodes, and wireless connections to other distribution nodes and to .

DN — See .

Fixed wireless access — Networking technology that provides high-speed network access to a fixed location using a radio connection.

FWA — See [Fixed wireless network](#).

GPON — Gigabit Passive Optical Network. A high-bandwidth mechanism for providing network access to a fibre optic backhaul network.

Golay index — An error correction mechanism used in wireless communications to mitigate co-channel interference. Wireless devices communicating on the same channel can mitigate interference by using different Golay indexes.

Hub-and-spoke — A network topology that involves central nodes with access to the backhaul network, and several nodes wirelessly connected to those central nodes.

Initiator — The that initially establishes a link with a remote device. By default, the initiator is the radio interface with the lower MAC address. See also [responder](#).

MCS — Modulation Coding Scheme. AltoPlex devices use a weighted MCS value of 2-12. MCS is prioritized in AltoPlex devices. MCS and [TX power](#) are adjusted automatically based on Power/packet Error Rate (PER). A link will stay at MCS 9 when minimal network traffic is observed.

Node — A single AltoPlex device in a multi-device installation.

NTP — Network Time Protocol. Enables the synchronization of a device's time to an upstream NTP server.

Point-to-point — A network topology in which two devices are directly connected to each other.

- Point-to-multipoint** — A network topology in which multiple devices are connected to a central node. In a point-to-multipoint network, AltoPlex [distribution nodes](#) support one [DN link](#) and up to fifteen [CN links](#).
- Polarity** — Polarity is a mechanism of [TDMA](#) used in determining when to transmit or receive during a timing cycle. Polarity is either odd or even.
- P2P, PtP** — See [point-to-point](#).
- PtMP, PMP** — See [point-to-multipoint](#).
- Point of presence** — The location or facility that connects to the Internet. Often this may be an equipment cabinet or similar location with fiber access to the primary network and/or the internet.
- PoP** — See [point of presence](#).
- PoP node** — The distribution node (or nodes) that is directly connected to the primary network and/or the internet. This distinction is important for optimizing traffic when designing network topology. During deployment, the PoP node devices are the first installed. During firmware upgrades, they are typically the last upgraded.
- Rebeamform** — A process by which a low-performing wireless connection between two AltoPlex devices is replaced with another wireless connection.
- Responder** — An AltoPlex device that does not initially establish a link with another device, but instead responds a link initiation request from an [initiator](#) device. By default, the responder is the radio interface with the higher MAC address. This information may be useful for network design, and in rare cases during troubleshooting after a power outage.
- Ring topology** — A network topology in which devices are connected in a circular closed loop.
- RSSI** — Received Signal Strength Indicator. A measurement of how well a device can receive signals from external wireless devices.
- SNMP** — Simple Network Management Protocol. Used to monitor and report on all the devices in your network.
- TDMA** — Time Division Multiple Access, used with GPS synchronization for timing in AltoPlex devices.
- TX power** — Transmission power. Determines how powerful a transmitted signal is.

